

Chapter 246-272A WAC ON-SITE SEWAGE SYSTEMS

Last Update: 2/26/25

WAC

PURPOSE AND ADMINISTRATION

246-272A-0001 Purpose, objectives, and authority.
246-272A-0005 Administration.
246-272A-0007 Applicability.
246-272A-0010 Definitions.

GENERAL REQUIREMENTS

246-272A-0013 Local rules.
246-272A-0015 Local management plans.
246-272A-0025 Connection to public sewer system.

SEWAGE PRODUCTS AND TECHNOLOGIES

246-272A-0100 Sewage technologies.
246-272A-0110 Proprietary treatment products—Eligibility for registration.
246-272A-0120 Proprietary treatment product registration—Process and requirements.
246-272A-0130 Bacteriological reduction.
246-272A-0140 Proprietary distribution products—Certification requirements.
246-272A-0145 Proprietary distribution product registration—Process and requirements.
246-272A-0170 Product development permits.

SPECIFIC REQUIREMENTS

246-272A-0200 Permit requirements.
246-272A-0210 Location.
246-272A-0220 Soil and site evaluation.
246-272A-0230 Design requirements—General.
246-272A-0232 Design requirements—Septic tank sizing.
246-272A-0233 Design requirements—Pump chambers.
246-272A-0234 Design requirements—Soil dispersal components.
246-272A-0238 Design requirements—Facilitate operation, monitoring and maintenance.
246-272A-0240 Holding tank sewage systems.
246-272A-0250 Installation.
246-272A-0260 Inspection.
246-272A-0265 Record drawings.
246-272A-0270 Operation, monitoring, and maintenance—Owner responsibilities.
246-272A-0275 Operation, monitoring, and maintenance—Food service establishments.
246-272A-0278 Remediation.
246-272A-0280 Repair of failures.
246-272A-0282 Minor repair of malfunctions.
246-272A-0290 Expansions.
246-272A-0300 Abandonment.
246-272A-0310 Septage management.
246-272A-0320 Developments, subdivisions, and minimum land area requirements.
246-272A-0340 Approval of installers, pumpers, and maintenance service providers.
246-272A-0400 Technical advisory group (TAG).
246-272A-0410 Policy advisory group.
246-272A-0420 Waivers.
246-272A-0425 Required review of rules.
246-272A-0430 Enforcement.
246-272A-0440 Notice of decision—Adjudicative proceeding.
246-272A-0450 Severability.

DISPOSITION OF SECTIONS FORMERLY CODIFIED IN THIS CHAPTER

246-272A-0020 Applicability. [Statutory Authority: RCW 43.20.050. WSR 05-15-119, § 246-272A-0020, filed 7/18/05, effective 9/15/05.] Repealed by WSR 24-06-046, filed 3/1/24, effective 4/1/25. Statutory Authority: RCW 43.20.050(3), 43.20.065, chapters 70A.105 and 70A.110 RCW.

246-272A-0125 Transition from the list of approved systems and products to the registered list—Treatment products. [Statutory Authority: RCW 43.20.050. WSR 05-15-119, § 246-272A-0125, filed 7/18/05, effective 9/15/05.] Repealed by WSR 24-06-046, filed 3/1/24, effective 4/1/25. Statutory Authority: RCW 43.20.050(3), 43.20.065, chapters 70A.105 and 70A.110 RCW.

246-272A-0135 Transition from the list of approved systems and products to the registered list—Bacteriological reduction. [Statutory Authority: RCW 43.20.050. WSR 05-15-119, § 246-272A-0135, filed 7/18/05, effective 9/15/05.] Repealed by WSR 24-06-046, filed 3/1/24, effective 4/1/25. Statutory Authority: RCW 43.20.050(3), 43.20.065, chapters 70A.105 and 70A.110 RCW.

246-272A-0150 Transition from the list of approved systems and products to the registered list—Distribution products. [Statutory Authority: RCW 43.20.050. WSR 05-15-119, § 246-272A-0150, filed 7/18/05, effective 9/15/05.] Repealed by WSR 24-06-046, filed 3/1/24, effective 4/1/25. Statutory Authority: RCW 43.20.050(3), 43.20.065, chapters 70A.105 and 70A.110 RCW.

246-272A-0175 Transition from the experimental system program to application for product registration. [Statutory Authority: RCW 43.20.050. WSR 05-15-119, § 246-272A-0175, filed 7/18/05, effective 9/15/05.] Repealed by WSR 24-06-046, filed 3/1/24, effective 4/1/25. Statutory Authority: RCW 43.20.050(3), 43.20.065, chapters 70A.105 and 70A.110 RCW.

PURPOSE AND ADMINISTRATION

WAC 246-272A-0001 Purpose, objectives, and authority. (1) The purpose of this chapter is to protect the public health by minimizing:

(a) The potential for public exposure to sewage from on-site sewage systems (OSS); and

(b) Adverse effects to public health that discharges from OSS may have on ground and surface waters.

(2) This chapter regulates the location, design, installation, operation, maintenance, and monitoring of OSS to:

(a) Achieve effective long-term sewage treatment and effluent dispersal; and

(b) Limit the discharge of contaminants to waters of the state.

(3) The state board of health is authorized under RCW 43.20.050 to establish minimum requirements for the department of health and local boards of health, and consistent with RCW 43.70.310 integrating the preservation of public health with protection of the environment in order to endorse policies in common.

(4) This chapter is intended to coordinate with other applicable statutes and rules for the design of OSS under chapter 18.210 RCW and chapter 196-33 WAC.

(5) This chapter is intended to coordinate with other applicable statutes for land use planning under chapters 36.70 and 36.70A RCW, and the statutes for subdivision of land under chapter 58.17 RCW.

(6) The local health officer may designate low-lying marine shorelines in their jurisdiction.

[Statutory Authority: RCW 43.20.050(3), 43.20.065, chapters 70A.105 and 70A.110 RCW. WSR 24-06-046, § 246-272A-0001, filed 3/1/24, effective 4/1/25. Statutory Authority: RCW 43.20.050. WSR 05-15-119, § 246-272A-0001, filed 7/18/05, effective 9/15/05.]

WAC 246-272A-0005 Administration. The local health officers and the department shall administer this chapter under the authority and requirements of chapters 70.05, 70.08, 70.46, 70A.105, 70A.110, and 43.70 RCW. RCW 70.05.060(7) authorizes local health officers to charge fees for the administration of this chapter.

[Statutory Authority: RCW 43.20.050(3), 43.20.065, chapters 70A.105 and 70A.110 RCW. WSR 24-06-046, § 246-272A-0005, filed 3/1/24, effective 4/1/25. Statutory Authority: RCW 43.20.050. WSR 05-15-119, § 246-272A-0005, filed 7/18/05, effective 9/15/05.]

WAC 246-272A-0007 Applicability. (1) The local health officer:

(a) Shall apply this chapter to OSS for treatment, siting, design, installation, and operation and maintenance measures treating sewage and dispersing effluent from residential sources with design flows up to 3,500 gallons per day;

(b) May apply this chapter to OSS for nonresidential sources of sewage if treatment, siting, design, installation, and operation and maintenance measures provide treatment and effluent dispersal equal to that required of residential sources;

(c) May not apply this chapter to industrial wastewater.

(2) The department shall apply the requirements of this chapter for the registration of proprietary treatment and distribution products.

(3) A valid OSS design approval, or installation permit issued prior to the effective date of these rules:

(a) Shall be acted upon in accordance with the requirements of this chapter in force at the time of issuance;

(b) Remains valid for a period of not more than five years from the date of approval or issuance, or remains valid for an additional year beyond the effective date of this chapter, whichever has the most lenient expiration date; and

(c) May be modified to include additional requirements if the health officer determines that a serious threat to public health exists.

(4) This chapter does not apply to facilities regulated as reclaimed water use under chapters 90.46 RCW and 173-219 WAC.

[Statutory Authority: RCW 43.20.050(3), 43.20.065, chapters 70A.105 and 70A.110 RCW. WSR 24-06-046, § 246-272A-0007, filed 3/1/24, effective 4/1/25.]

WAC 246-272A-0010 Definitions. The definitions used in this section apply throughout this chapter unless the context clearly indicates otherwise:

(1) "Additive" means a commercial product added to an OSS intended to affect the performance or aesthetics of an OSS.

(2) "ANSI" means American National Standards Institute.

(3) "Approved" means a written statement of acceptability issued by the local health officer or the department.

(4) "Bank" means any naturally occurring slope greater than 100 percent (45 degrees) and extending vertically at least five feet from the toe of the slope to the top of the slope as follows:

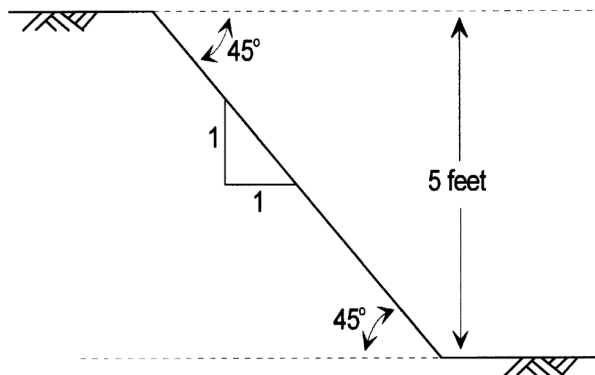

(5) "Bed" means a soil dispersal component consisting of an excavation with a width greater than three feet.

(6) "BL" means bacterial level.

(7) "Black water" means any waste from toilets or urinals.

(8) "BOD" means biochemical oxygen demand, typically expressed in mg/L.

(9) "Building drain" means that part of the lowest piping of a building's drainage system that receives the discharge of sewage from pipes inside the walls of the building and conveys it to the building sewer beginning two feet outside the building wall.

(10) "Building sewer" means that part of the horizontal piping of a drainage system extending from the building drain, which collects sewage from all the drainage pipes inside a building, to an OSS. It begins two feet outside the building wall and conveys sewage from the building drain to the OSS.

(11) "CBOD₅" means carbonaceous biochemical oxygen demand, typically expressed in mg/L.

(12) "Cesspool" means a pit receiving untreated sewage and allowing the liquid to seep into the surrounding soil or rock.

(13) "Conforming system" means any OSS or component, meeting any of the following criteria:

(a) In full compliance with new construction requirements under this chapter; or

(b) Approved, installed, and operating in accordance with requirements of previous editions of this chapter; or

(c) Permitted by the waiver process under WAC 246-272A-0420.

(14) "Cover material" means soil placed over a soil dispersal component composed predominately of mineral material with no greater than 10 percent organic content. Cover material may contain an organic surface layer for establishing a vegetative landscape to reduce soil erosion.

(15) "Cuts" means any artificially formed slope greater than 100 percent (45 degrees) and extending vertically at least five feet from the toe of the slope to the top of the slope as follows:

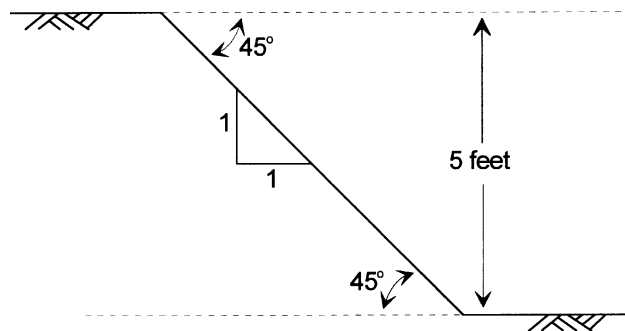

(16) "Department" means the Washington state department of health.

(17) "Designer" means a person who matches site and soil characteristics with appropriate on-site sewage technology. Throughout this chapter this term applies to both OSS designers licensed under chapter 18.210 RCW and professional engineers licensed under chapter 18.43 RCW.

(18) "Design flow" means the maximum volume of sewage a residence, structure, or other facility is estimated to generate in a 24-hour period. It incorporates both an operating capacity and a surge capacity for the OSS during periodic heavy use events. The sizing and design of the OSS components are based on the design flow.

(19) "Detention pond" means an earthen impoundment used for the collection and temporary storage of stormwater runoff.

(20) "Development" means the creation of a residence, structure, facility, subdivision, site, area, or similar activity resulting in the production of sewage.

(21) "Disinfection" means the process of destroying pathogenic microorganisms in sewage through the application of ultraviolet light, chlorination, or ozonation.

(22) "Distribution technology" means any arrangement of equipment or materials that distributes sewage within an OSS.

(23) "Drainrock" means clean washed gravel or crushed rock ranging in size from three-quarters inch to two and one-half inches and containing no more than two percent by weight passing a US No. 8 sieve and no more than one percent by weight passing a US No. 200 sieve.

(24) "DS&G" means department standards and guidance.

(25) "*E. coli*" means *Escherichia coli* bacteria. Counts of these organisms are typically used to indicate potential contamination from sewage or to describe a level of needed disinfection, typically expressed as colony forming units/100 mL.

(26) "Effluent" means liquid discharged from a sewage tank or other OSS component.

(27) "EPA" means United States Environmental Protection Agency.

(28) "Expanding clay" means a clay soil with the mineralogy of clay particles, such as those found in the Montmorillonite/Smectite Group, which causes the clay particles to expand when they absorb water, closing the soil pores, and contract when they dry out.

(29) "Expansion" means a change in a residence, facility, site, or use that:

(a) Causes the sewage quantity or quality to exceed the existing design flow of the OSS, for example, when a residence is increased from two to three bedrooms or a change in use from an office to a restaurant; or

(b) Reduces the treatment or dispersal capability of the existing OSS or the reserve area, for example, when a building is placed over a reserve area.

(30) "Extremely gravelly" means soil with 60 percent or more, but less than 90 percent rock fragments by volume.

(31) "Failure" means a condition of an OSS or component that threatens the public health by inadequately treating sewage or by creating a potential for direct or indirect contact between sewage and the public. Examples of failure include:

(a) Sewage on the surface of the ground;

(b) Sewage backing up into a structure caused by slow soil absorption of septic tank effluent;

(c) Sewage leaking from a sewage tank or collection system;

(d) Cesspools or seepage pits where evidence of groundwater or surface water quality degradation exists;

(e) Inadequately treated effluent contaminating groundwater or surface water; or

(f) Noncompliance with standards stipulated on the permit.

(32) "Fecal coliform" or "FC" means bacteria common to the digestive systems of warm-blooded animals that are cultured in standard tests. Counts of these organisms are typically used to indicate potential contamination from sewage or to describe a level of needed disinfection typically expressed in colony forming units/100 mL.

(33) "Fill" means unconsolidated material that:

(a) Meets soil types 1-6 textural criteria and is used as part of a soil dispersal component;

(b) Is used to change grade or to enhance surface water diversion; or

(c) Is any other human-transported material.

(34) "Flood plain" means an area that is low-lying and adjacent to a stream or river that is covered by water during a flood.

(35) "GPD" means gallons per day.

(36) "Gravelly" means soils with 15 percent or more, but less than 35 percent rock fragments by volume.

(37) "Greywater" means sewage from any source in a residence or structure that has not come into contact with toilet or urinal wastes, including bathtubs, showers, bathroom sinks, washing machines, dishwashers, and kitchen sinks.

(38) "Groundwater" means subsurface water occupying the zone of saturated soil, permanently, seasonally, or as the result of the tides. Indications of groundwater may include:

(a) Water seeping into or standing in an open excavation from the soil surrounding the excavation or monitoring ports.

(b) Spots or blotches of different color or shades of color interspersed with a dominant color in soil, caused by reduction and oxidation of iron. These color patterns are redoximorphic features, commonly referred to as mottling. Redoximorphic features often indicate the intermittent presence of groundwater and may indicate poor aeration and impeded drainage.

(39) "Holding tank sewage system" means an OSS that incorporates a sewage tank without a discharge outlet, the services of a sewage pumper/hauler, and the offsite treatment and disposal for the sewage generated.

(40) "Hydraulic loading rate" means the amount of effluent applied to a given treatment step, expressed as gallons per square foot per day or gal/sq.ft./day.

(41) "Industrial wastewater" means the water or liquid carried waste from an industrial process. These wastes may result from any process or activity of industry, manufacture, trade or business, from the development of any natural resource, or from animal operations such as feedlots, poultry houses, or dairies. Industrial wastewater includes contaminated stormwater and leachate from solid waste facilities.

(42) "Infiltration pond" means an earthen impoundment used for the collection, temporary storage, and infiltration of stormwater runoff.

(43) "Infiltrative surface" means the surface within a treatment component or soil dispersal component to which effluent is applied and through which effluent moves into original, undisturbed soil or other porous treatment media.

(44) "Installer" means a person approved by the local health officer to install an OSS or OSS components.

(45) "Local health officer" means the health officer of the city, county, or city-county health department or district within the state of Washington, or a representative authorized by and under the direct supervision of the local health officer, as defined in chapter 70.05 RCW.

(46) "LOSS" means a large on-site sewage system under chapter 246-272B WAC.

(47) "Maintenance" means the actions necessary to keep the OSS components functioning as designed.

(48) "Maintenance service provider" means a management entity certified by the local health officer and conducts a comprehensive analysis of an OSS.

(49) "Malfunction" means a damaged or deficient previously conforming OSS component that may be corrected by means of a minor repair.

(50) "Massive structure" means the condition of a soil layer in which the layer appears as a coherent or solid mass not separated into peds of any kind.

(51) "mg/L" means milligrams per liter.

(52) "mL" means milliliter.

(53) "Minimum usable land area" means the minimum land area within the minimum lot size required per development using an OSS, which is based on soil type and type of water supply. Minimum usable land area is free of all physical restrictions and meet minimum vertical and horizontal separations.

(54) "Minor repair" means the repair or replacement of any of the following existing damaged or malfunctioning OSS components except that the repair or replacement of a sewage tank, treatment component, or soil dispersal component is not considered a minor repair:

(a) Control panels;

(b) Building sewers;

(c) Any other portions of tightline in the OSS;

(d) Risers and riser lids;

(e) Sewage tank baffles;

(f) Effluent filters;

(g) Sewage tank pumps and lids;

(h) Pump control floats; and

(i) OSS inspection boxes and ports.

(55) "Moderate structure" means well-formed distinct peds evident in undisturbed soil. When disturbed, soil material parts into a mixture of whole peds, broken peds, and material that is not in peds.

(56) "Modification" means the alteration of an existing OSS component that does not result in an expansion of the system. A modification is not considered a repair.

(57) "Monitoring" means periodic or continuous checking of an OSS, which is performed by observations and measurements, to determine if the system is functioning as intended and if system maintenance is needed. Monitoring also includes maintaining accurate records that document monitoring activities.

(58) "NSF" means NSF International.

(59) "O&G" means oil and grease, a component of sewage typically originating from food stuffs such as animal fats or vegetable oils, or consisting of compounds of alcohol or glycerol with fatty acids such as soaps and lotions, typically expressed in mg/L.

(60) "Operating capacity" means the average daily volume of sewage an OSS can treat and disperse on a sustained basis. The operating capacity, which is lower than the design flow, is an integral part of the design and is used as an index in OSS monitoring.

(61) "Ordinary high-water mark" means the mark on lakes, streams, springs, and tidal waters, found by examining the beds and banks and ascertaining where the presence and action of waters are so common and usual, and so long continued in all ordinary years, as to mark upon the soil a character distinct from that of the abutting upland with respect to vegetation, as that condition exists on the effective date of this chapter, or as it may naturally change thereafter. The follow-

ing conditions apply where the ordinary high-water mark cannot be found:

(a) The ordinary high-water mark adjoining marine water is the elevation at mean higher high tide; and

(b) The ordinary high-water mark adjoining freshwater is the line of mean high water.

(62) "OSS" means on-site sewage system, an integrated system of components, located on or nearby the property it serves, which conveys, stores, treats, and provides subsurface soil treatment and dispersal of sewage. It consists of a collection system, a treatment component or treatment component sequence, and a soil dispersal component. An OSS also refers to a holding tank sewage system or other system that does not have a soil dispersal component. The term "on-site sewage system (OSS)" does not include any system regulated by a water quality discharge permit issued under chapter 90.48 RCW.

(63) "PAG" means policy advisory group.

(64) "PDP" means product development permit.

(65) "Ped" means a unit of soil structure such as blocks, column, granule, plate, or prism formed by natural processes.

(66) "Person" means any individual, corporation, company, association, society, firm, partnership, joint stock company, or any governmental agency, or the authorized agents of these entities. For the purposes of WAC 246-272A-0430 and 246-272A-0440, a person is defined to include:

(a) Applicant;

(b) Reapplicant;

(c) Permit holder; or

(d) Any individual associated with (a), (b) or (c) of this subsection including, but not limited to:

(i) Board members;

(ii) Officers;

(iii) Managers;

(iv) Partners;

(v) Association members;

(vi) Agents; and

(vii) Third persons acting with the knowledge of such persons.

(67) "Planned unit development" means a subdivision characterized by a unified site design, clustered residential units or commercial units, and areas of common open space.

(68) "Platy structure" means soil that contains flat peds that lie horizontally and often overlap. This type of structure impedes the vertical movement of water.

(69) "Pressure distribution" means a system of small diameter pipes equally distributing effluent throughout an OSS, as described in the *DS&G for Pressure Distribution Systems, 2022*. A subsurface drip system is considered a pressure distribution system.

(70) "Professional engineer" means a person who is currently licensed as an engineer under the provisions of chapter 18.43 RCW.

(71) "Proprietary product" means a sewage treatment and distribution technology, method, or material subject to a patent or trademark.

(72) "Public domain technology" means a sewage treatment and distribution technology, method, or material not subject to a patent or trademark.

(73) "Public sewer system" means a sewerage system:

(a) Owned or operated by a city, town, municipal corporation, county, or other approved ownership consisting of a collection system

and necessary trunks, pumping facilities and a means of final treatment and disposal; and

(b) Approved by or under permit from the department of ecology, the department of health, or a local health officer.

(74) "Puget Sound counties" means Clallam, Island, Kitsap, Jefferson, Mason, San Juan, Seattle-King, Skagit, Snohomish, Tacoma-Pierce, Thurston, and Whatcom. All other counties are defined as non-Puget Sound counties.

(75) "Pump chamber" means a watertight receptacle placed after a septic tank, sewage tank, or other treatment facility that contains the required controls and alarms to convey sewage effluent to a treatment or dispersal component.

(76) "Pumper" means a person approved by the local health officer to remove and transport sewage or septage from an OSS.

(77) "Record drawing" means an accurate graphic and written record of the location and features of the OSS that are needed to properly monitor, operate, and maintain that system. Also known as an "as-built" drawing.

(78) "Remediation" means any action, approved by the local health officer, which attempts to restore the function of a previously conforming OSS dispersal component that has failed. Remediation is not considered:

(a) A minor repair;

(b) A repair;

(c) An additive; or

(d) A treatment or distribution technology that allows the OSS to meet a specific treatment level.

(79) "Repair" means the relocation, replacement, or reconstruction of a failed OSS, or any OSS components not included in the list for a minor repair, which have failed in order to restore the OSS to a nonfailure status.

(80) "Reserve area" means an area of land approved for the installation of a conforming OSS that is protected and maintained for replacement of the OSS upon its failure.

(81) "Residential sewage" means sewage having the constituency and quality typical of residential septic tank effluent consistent with treatment level E identified in Table III in WAC 246-272A-0110.

(82) "Restrictive layer" means a stratum impeding the vertical movement of water, air, and growth of plant roots, such as hardpan, claypan, fragipan, caliche, some compacted soils, bedrock, and unstructured clay soils.

(83) "Rock fragment" means rock or mineral fragments having a diameter of two millimeters or more. Examples include, gravel, cobbles, stones, and boulders.

(84) "Seepage pit" means an excavation more than three feet deep where the sidewall of the excavation is designed to dispose of septic tank effluent. Seepage pits are also known as dry wells.

(85) "Septage" means liquid or solid material removed from sewage tanks, cesspools, portable toilets, type III marine sanitation devices, vault toilets, pit toilets, recreational vehicle holding tanks, or similar systems that receive only domestic sewage.

(86) "Septic tank" means a watertight treatment receptacle receiving the discharge of sewage from a building sewer or sewers, designed and constructed to separate settleable and floating solids from the liquid, detention and anaerobic digestion of the organic matter, prior to discharge of the liquid.

(87) "Sewage" means any urine, feces, and the water carrying human wastes, including kitchen, bath, and laundry wastes from residences, buildings, industrial establishments, or other places.

(88) "Sewage quality" means contents in sewage that include:

(a) CBOD₅, TSS, and O&G;

(b) Other parameters that may adversely affect treatment. Examples include pH, temperature, and dissolved oxygen; or

(c) Other constituents that create concerns due to specific site sensitivity. Examples include fecal coliform, *E. coli*, phosphorus, and nitrogen.

(89) "Sewage tank" means a prefabricated or cast-in-place septic tank, pump chamber, dosing chamber, holding tank, grease interceptor, recirculating filter tank or any other tanks as they relate to OSS including tanks for use with proprietary products.

(90) "Soil dispersal component" means a technology that releases effluent from a treatment component into the soil for dispersal, final treatment and recycling.

(91) "Soil log" means a detailed description of soil characteristics providing information on the soil's capacity to act as an acceptable treatment and dispersal medium for sewage.

(92) "Soil scientist" means a person certified by the American Society of Agronomy as a Certified Professional Soil Scientist.

(93) "Soil type" means one of seven numerical classifications of fine earth particles and rock fragments as described in WAC 246-272A-0220 (2) (e).

(94) "Standard methods" means the *23rd Edition of Standard Methods for the Examination of Water and Wastewater*, prepared and published jointly by the American Public Health Association, the American Water Works Association and the Water Environment Federation.

(95) "Strong structure" means peds are distinct in undisturbed soil. They separate cleanly when soil is disturbed, and the soil material separates mainly into whole peds when removed.

(96) "Subdivision" means a division of land or creation of lots or parcels, described under chapter 58.17 RCW, including both long and short subdivisions, planned unit developments, and mobile home parks.

(97) "Subsurface drip system" means an efficient pressurized wastewater distribution system that can deliver small, precise doses of effluent to soil surrounding the drip distribution piping, also known as dripline, as described in the *DS&G for Subsurface Drip Systems*, 2020.

(98) "SSAS" means a subsurface soil absorption system that is a soil dispersal component of trenches or beds containing either a distribution pipe within a layer of drainrock covered with a geotextile, or an approved gravelless distribution technology, designed and installed in suitable soil, with either gravity or pressure distribution of the treatment component effluent.

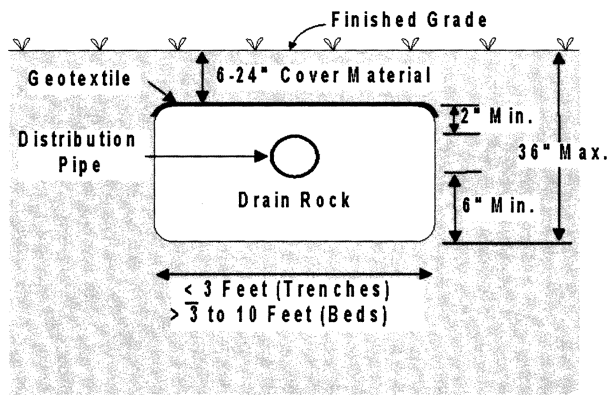

(99) "Suitable" means original, undisturbed, unsaturated soil of soil types 1-6 with at least the vertical separation established in this chapter.

(100) "Surface water" means any fresh or marine body of water flowing or contained in natural or artificial unlined depressions for significant periods of the year, including natural and artificial lakes, ponds, springs, rivers, streams, swamps, marshes, irrigation canals, and tidal waters.

(101) "TAG" means the technical advisory group established in WAC 246-272A-0400.

(102) "Timed dosing" means delivery of discrete volumes of sewage at prescribed time intervals.

(103) "TN" means total nitrogen, typically expressed in mg/L.

(104) "Treatment component" means a technology that treats sewage in preparation for further treatment or dispersal into the soil environment. Some treatment components, such as mound systems, incorporate a soil dispersal component in lieu of separate treatment and soil dispersal components.

(105) "Treatment component sequence" means any series of treatment components that discharges treated sewage to the soil dispersal component.

(106) "Treatment level" means one of the following levels (A, B, C, BL1, BL2, BL3, E, & N) to:

(a) Identify treatment component performance demonstrated through requirements specified in WAC 246-272A-0110; and

(b) Match site conditions of vertical separation and soil type with treatment components.

(107) "Trench" means a soil dispersal component consisting of an excavation with a width of three feet or less.

(108) "TSS" means total suspended solids, a measure of all suspended solids in a liquid, typically expressed in mg/L.

(109) "Unit volume of sewage" means:

(a) Flow from a single-family residence;

(b) Flow from a mobile home site in a mobile home park; or

(c) Four hundred fifty gallons of sewage per day where the proposed development is not single-family residences or a mobile home park.

(110) "Unknown OSS" means an OSS that was installed without the knowledge or approval of the local health jurisdiction, including those that were installed before such approval was required.

(111) "Unpermitted sewage discharge" means the discharge of sewage or treated effluent from an unknown OSS.

(112) "Vertical separation" means the depth of suitable soils between the bottom infiltrative surface of a soil dispersal component

and the highest seasonal water table, a restrictive layer, or soil type 7 as illustrated below by the profile drawing of subsurface soil absorption systems:

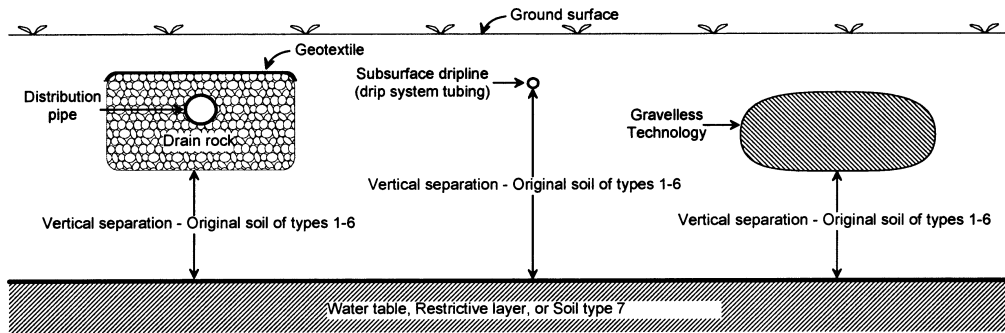

(113) "Very gravelly" means soil containing 35 percent or more, but less than 60 percent rock fragments by volume.

(114) "Water supply protection zone" means the land area around each existing or proposed well site to protect the water supply from contamination.

(115) "Water table" means the upper surface of the groundwater, whether permanent or seasonal. Also see "groundwater" as defined in this section.

(116) "Well" means any excavation that is constructed when the intended use of the well is for the location, diversion, artificial recharge, observation, monitoring, dewatering or withdrawal of groundwater for agricultural, municipal, industrial, domestic, or commercial use. The following are not considered a well:

(a) A temporary observation or monitoring well used to determine the depth to a water table for locating an OSS;

(b) An observation or monitoring well used to measure the effect of an OSS on a water table;

(c) An interceptor or curtain drain constructed to lower a water table; and

(d) A dewatering well used temporarily for the purpose of a sewage tank or pump chamber installation.

[Statutory Authority: RCW 43.20.050(3), 43.20.065, chapters 70A.105 and 70A.110 RCW. WSR 24-06-046, § 246-272A-0010, filed 3/1/24, effective 4/1/25. Statutory Authority: RCW 43.20.050. WSR 05-15-119, § 246-272A-0010, filed 7/18/05, effective 9/15/05.]

GENERAL REQUIREMENTS

WAC 246-272A-0013 Local rules. (1) The local health officer shall enforce the requirements of this chapter until a local board of health adopts local OSS regulations. A local board of health may adopt and enforce local rules governing OSS when the local regulations are:

(a) Consistent with, and at least as stringent as this chapter; and

(b) Approved by the department prior to the effective date of local regulations.

(2) To apply for department approved local OSS regulations a local board of health shall submit the proposed local regulations to the department.

(3) Within 90 days of receipt of proposed local regulations, the department shall:

(a) Approve the proposed regulations; or

(b) Deny the proposed regulations if the department determines local regulations are not consistent with this chapter or less stringent than this chapter and provide specific reasons for the denial.

(4) Upon receipt of department approval, or after 90 days if the department fails to act, the local board may implement adopted regulations. The local board shall provide a copy of the adopted local regulations to the department.

(5) If the department denies approval of local regulations, the local board of health may:

(a) Resubmit revised regulations that address the specific reasons for the denial for department consideration; or

(b) Submit a request to the department to review its denial within 120 days from the date the local board of health receives the specific reasons for the denial.

(6) Upon receipt of request for review of the department denial, the department shall:

(a) Acknowledge the receipt of the request within 30 days; and

(b) Form a mutually acceptable advisory panel to review the department denial and reach an agreement within a reasonable time. The panel shall consist of:

(i) One representative from the department;

(ii) One representative from a local health jurisdiction other than that which requested the review; and

(iii) One member of the TAG.

(7) If good faith efforts to reach agreement are unsuccessful between the department and a local board of health, the local board of health may appeal the denial to the Washington state board of health for resolution.

(8) Nothing in this chapter shall prohibit the adoption and enforcement of more stringent regulations by a local board of health.

[Statutory Authority: RCW 43.20.050(3), 43.20.065, chapters 70A.105 and 70A.110 RCW. WSR 24-06-046, § 246-272A-0013, filed 3/1/24, effective 4/1/25.]

WAC 246-272A-0015 Local management plans. (1) The local health officer for each Puget Sound county shall develop a written local management plan to provide guidance to the local health jurisdiction regarding development and management activities for all OSS within the jurisdiction. The department will review the existing OSS local management plans for all Puget Sound counties within two years of the effective date of the rule. If the department determines a plan revision is necessary upon review, the local health officer shall revise the local management plan for all OSS within the local health jurisdiction consistent with subsection (2) of this section.

(2) At a minimum, the local management plan for Puget Sound counties must specify how the local health jurisdiction will:

(a) Progressively develop and maintain an inventory including the type and location of all known OSS in operation within the jurisdiction;

(b) Identify any areas where OSS could pose an increased public health risk. The following areas shall be given priority in this activity:

- (i) Shellfish protection districts or shellfish growing areas;
 - (ii) Sole source aquifers as designated by the EPA;
 - (iii) Areas in which aquifers used for potable water as designated under the Washington State Growth Management Act under chapter 36.70A RCW are critically impacted by recharge;
 - (iv) Designated wellhead protection areas in Group A public water supplies under chapter 246-290 WAC;
 - (v) Up-gradient areas directly influencing water recreation facilities designated for swimming in natural waters with artificial boundaries within the waters as described by the Water Recreation Facilities Act under chapter 70.90 RCW;
 - (vi) Areas designated as special protection areas under WAC 173-200-090;
 - (vii) Wetland areas under production of crops for human consumption;
 - (viii) Frequently flooded areas including areas delineated by the Federal Emergency Management Agency or as designated under the Washington State Growth Management Act under chapter 36.70A RCW;
 - (ix) Areas where nitrogen has been identified as a contaminant of concern including, but not limited to, the marine waters of Puget Sound;
 - (x) Areas where phosphorous has been identified as a contaminant of concern;
 - (xi) Areas where sea level rise may impact adequate horizontal separations to surface water; and
 - (xii) Other areas designated by the local health officer.
- (c) Identify operation, maintenance, and monitoring requirements commensurate with risks posed by OSS within the geographic areas identified in (b) of this subsection;
- (d) Educate OSS owners about their responsibilities to perform OSS operation and maintenance, including information for owners to complete any inspection required by WAC 246-272A-0270;
- (e) Maintain records required under this chapter, including all operation and maintenance activities as identified;
- (f) Enforce OSS owner permit application, operation, monitoring and maintenance and failure repair requirements in WAC 246-272A-0200 (2), 246-272A-0260, 246-272A-0270, 246-272A-0275, and 246-272A-0280;
- (g) Describe the capacity of the local health jurisdiction to fund the local management plan, which includes a summary of program expenditures by activity, source of funds, a strategy to fill any funding gaps, and the ability to find failing and unknown systems; and
- (h) Verify that the local management plan was developed in coordination with the comprehensive land use plan of the entities governing development within the local health jurisdiction.
- (3) The department shall review the local management plan for Puget Sound counties at least once every five years. If the department determines plan revision is necessary upon review of the local management plan described in subsection (2) of this section, the department shall notify the local health officer of their findings.
- (4) The local health officer for Puget Sound counties shall:
- (a) Review and update the local management plan, as necessary, or at least once every five years;
 - (b) If after the review the local management plan is updated, provide an opportunity for public input on the local management plan;
 - (c) Following local board of health approval, submit the local management plan to the department for review;
 - (d) Implement the local management plan;

(e) Submit an annual report to the department including all of the following in a format specified by the department:

- (i) Number of OSS;
- (ii) Number of unknown OSS identified;
- (iii) Number of failures found;
- (iv) Number of failures repaired; and
- (v) Status of compliance with inspections required by WAC 246-272A-0270;

(f) Supply a copy of the local management plan to the entities responsible for land use planning and development regulations in the local health jurisdiction.

(5) The local health officer for a non-Puget Sound county shall develop a written local management plan that will provide guidance to the local health jurisdiction regarding development and management activities for all OSS within the jurisdiction. At a minimum the plan shall include:

(a) A description of the capacity of the local health jurisdiction to provide education and operation and maintenance information for all types of systems in use within the jurisdiction;

(b) A description of how the local health officer will remind and encourage homeowners to complete the operation and maintenance inspection required by WAC 246-272A-0270; and

(c) A description of the capacity of the local health jurisdiction to adequately fund the local OSS plan.

(6) In order to implement the plan described in subsections (1) and (5) of this section, the local health officer shall require the owner of the OSS to:

(a) Comply with additional requirements identified in the plan for the location, design, or performance; and

(b) Comply with the conditions of the operational permit if one is required.

(7) In order to implement the plan described in subsections (1) and (5) of this section, the local health officer may require the owner of the OSS to:

(a) Ensure additional maintenance and monitoring of the OSS;

(b) Provide dedicated easements for inspections, maintenance, and potential future expansion of the OSS; and

(c) Place a notice to title identifying any additional requirements for OSS operation, maintenance, and monitoring.

(8) The department shall maintain and update guidance and provide technical assistance to assist local health jurisdictions in local management plan development.

[Statutory Authority: RCW 43.20.050(3), 43.20.065, chapters 70A.105 and 70A.110 RCW. WSR 24-06-046, § 246-272A-0015, filed 3/1/24, effective 4/1/25. Statutory Authority: RCW 43.20.050. WSR 05-15-119, § 246-272A-0015, filed 7/18/05, effective 9/15/05.]

WAC 246-272A-0025 Connection to public sewer system. (1) Upon the failure of an existing OSS within the service area of a sewer utility, the local health officer shall:

(a) Permit the repair or replacement of the OSS only if a conforming OSS can be designed and installed, excluding OSS designed in compliance with or proposing to use Table X in WAC 246-272A-0280; or

(b) Require connection to a public sewer system if the sewer utility allows the connection and has adequate public sewer services

available within 200 feet from where the existing building drain connects to the existing building sewer, or where no building drain exists, within 200 feet from where the sewer line begins, as measured along the usual or most feasible route of access.

(2) The owner of a structure served by an OSS permitted as a repair under Table X in WAC 246-272A-0280 shall abandon the OSS as specified in WAC 246-272A-0300, and connect the structure to a public sewer system when:

(a) Connection is deemed necessary to protect public health by the local health officer;

(b) An adequate public sewer becomes available within 200 feet of the existing structure, or in cases where no building drain exists, within 200 feet from where the sewer for the building begins, as measured along the usual or most economically feasible route of access; and

(c) The sewer utility allows the sewer connection.

(3) Local boards of health may require a new development to connect to a public sewer system to protect public health.

(4) Local boards of health shall require new development or a development with a failing OSS to connect to a public sewer system if it is required by the comprehensive land use plan or development regulations.

[Statutory Authority: RCW 43.20.050(3), 43.20.065, chapters 70A.105 and 70A.110 RCW. WSR 24-06-046, § 246-272A-0025, filed 3/1/24, effective 4/1/25. Statutory Authority: RCW 43.20.050. WSR 05-15-119, § 246-272A-0025, filed 7/18/05, effective 9/15/05.]

SEWAGE PRODUCTS AND TECHNOLOGIES

WAC 246-272A-0100 Sewage technologies. (1) The department shall maintain standards and guidance for local health officers to permit sewage treatment and distribution technologies.

(2) Before the local health officer permits sewage technologies, the sewage technologies must be registered for use as described in this chapter, have standards for use as described or referenced in this chapter, or have DS&G describing sewage technologies uses as maintained by the department.

(3) The department may remove, restrict, or suspend a proprietary product's approval for use based on failure to meet required standards or conditions of approval or if the information provided by the manufacturer is false, erroneous, or unrepresentative of the approved product.

[Statutory Authority: RCW 43.20.050(3), 43.20.065, chapters 70A.105 and 70A.110 RCW. WSR 24-06-046, § 246-272A-0100, filed 3/1/24, effective 4/1/25. Statutory Authority: RCW 43.20.050. WSR 05-15-119, § 246-272A-0100, filed 7/18/05, effective 9/15/05.]

WAC 246-272A-0110 Proprietary treatment products—Eligibility for registration. (1) Manufacturers shall register a proprietary treatment product with the department using the process described in

WAC 246-272A-0120 before a local health officer may permit use of the product.

(2) To be eligible for product registration, manufacturers desiring to sell or distribute proprietary treatment products in Washington state shall:

(a) Verify product performance through testing using the testing protocol established in Table I of this section;

(b) Report product test results of influent and effluent sampling obtained throughout the testing period (including normal and stress loading phases) for evaluation of constituent reduction according to the requirements in Table II of this section;

(c) Demonstrate product performance according to the requirements in Table III of this section. All 30-day averages and geometric means obtained throughout the test period must meet the identified threshold values to qualify for registration at that threshold level; and

(d) Verify bacteriological reduction according to WAC 246-272A-0130 for product registration utilizing bacterial levels BL1, BL2, and BL3.

(3) Manufacturers verifying product performance through testing according to the following standards or protocols shall have product testing conducted by a testing facility accredited by ANSI:

(a) NSF/ANSI 40: Residential Wastewater Treatment Systems;

(b) NSF/ANSI 41: Non-Liquid Saturated Treatment Systems;

(c) NSF Protocol P157 Electrical Incinerating Toilets - Health and Sanitation;

(d) NSF/ANSI 245: Residential Wastewater Treatment Systems - Nitrogen Reduction; or

(e) NSF/ANSI 385: Residential Wastewater Treatment Systems - Disinfection Mechanics for Bacteriological Reduction described in WAC 246-272A-0130.

(4) Manufacturers verifying product performance through testing according to EPA Method 1664, Revision B and using a wastewater laboratory certified by the Washington department of ecology shall provide supporting information, including flow data, and influent and effluent quality sampling results from a minimum of three installations with similar design loading to demonstrate product performance to Category 2 standards.

(5) Treatment levels established in Table III of this section are intended to establish treatment product performance in a product testing setting under established protocols by qualified testing entities. Field compliance standards for proprietary treatment products shall follow the requirements in WAC 246-272A-0120(5).

(6) Manufacturers may submit a written request to substitute components of a registered product's construction in cases of supply chain shortage or similar manufacturing disruptions impacting installations, operation, or maintenance. The substitution request must include a report stamped, signed, and dated by a professional engineer demonstrating the substituted component will not negatively impact performance or diminish the effect of the treatment, operation, and maintenance of the original registered product. If approved, substitution is authorized until rescinded by the department.

Table I

Testing Requirements for Proprietary Treatment Products	
Treatment Component/Sequence Category	Required Testing Protocol
Category 1 Designed to treat septic tank effluent anticipated to be equal to or less than treatment level E.	NSF/ANSI 40—Residential Wastewater Treatment Systems (versions dated between January 2009 and May 31, 2021)
Category 2 Designed to treat effluent or sewage with sewage quality parameters anticipated to be greater than treatment level E. (Such as at restaurants, grocery stores, mini-marts, group homes, medical clinics, residences, etc.)	EPA Method 1664, Revision B (February 2010) and NSF/ANSI 40—Residential Wastewater Treatment Systems (versions dated between January 2009 and May 31, 2021)
Category 3 Black water component of residential sewage (such as composting* and incinerating** toilets).	NSF/ANSI 41: Non-Liquid Saturated Treatment Systems (Versions dated between February 2011 and May 31, 2021) **NSF Protocol P157 Electrical Incinerating Toilets - Health and Sanitation (April 2000)
Total Nitrogen Reduction in Categories 1 & 2 (Above)	NSF/ANSI 245: Residential Wastewater Treatment Systems - Nitrogen Reduction (Versions dated between January 2018 and May 31, 2021)

Table II

Test Results Reporting Requirements for Proprietary Treatment Products									
Treatment Component/Sequence Category	Testing Results Reported								
Category 1 Designed to treat septic tank effluent anticipated to be equal to or less than treatment level E.	<p>Report the following test results of influent and effluent sampling obtained throughout the testing period for evaluation of reduction of CBOD₅², and TSS:</p> <table border="0"> <tr> <td><input type="checkbox"/> Average</td> <td><input type="checkbox"/> Standard Deviation</td> </tr> <tr> <td><input type="checkbox"/> Minimum</td> <td><input type="checkbox"/> Maximum</td> </tr> <tr> <td><input type="checkbox"/> Median</td> <td><input type="checkbox"/> Interquartile Range</td> </tr> <tr> <td colspan="2"><input type="checkbox"/> 30-day Average (for each month)</td> </tr> </table> <p>For evaluation of bacteriological reduction performance.</p> <p>Report complete treatment component sequence testing as described in Table III, Category 1.</p> <p>For evaluation of performance meeting treatment level BL1:</p> <p>(1) Report fecal coliform test results of influent and effluent sampling by geometric mean from samples drawn within 30-day or monthly calendar periods, obtained from a minimum of three samples per week throughout the testing period. See WAC 246-272A-0130.</p> <p>(2) Report complete testing results for supplemental bacteriological reduction technology¹ when the required treatment levels for fecal coliform in Table III, Category 1 are not met by the primary proprietary treatment product.</p> <p>For evaluation of performance meeting treatment level BL2 or BL3:</p> <p>(1) Report fecal coliform test results of influent and effluent sampling by geometric mean from samples drawn within 30-day or monthly calendar periods, obtained from a minimum of three samples per week throughout the testing period as described in WAC 246-272A-0130; or</p> <p>(2) Report complete testing results for supplemental bacteriological reduction technology¹ when the required treatment levels for fecal coliform in Table III, Category 1 are not met by the primary proprietary treatment product.</p> <p>For all options, test report must also include the individual results of all samples drawn throughout the test period.</p>	<input type="checkbox"/> Average	<input type="checkbox"/> Standard Deviation	<input type="checkbox"/> Minimum	<input type="checkbox"/> Maximum	<input type="checkbox"/> Median	<input type="checkbox"/> Interquartile Range	<input type="checkbox"/> 30-day Average (for each month)	
<input type="checkbox"/> Average	<input type="checkbox"/> Standard Deviation								
<input type="checkbox"/> Minimum	<input type="checkbox"/> Maximum								
<input type="checkbox"/> Median	<input type="checkbox"/> Interquartile Range								
<input type="checkbox"/> 30-day Average (for each month)									

Test Results Reporting Requirements for Proprietary Treatment Products	
Category 2 Designed to treat effluent or sewage with sewage quality parameters anticipated to be greater than treatment level E. (Such as at restaurants, grocery stores, mini-marts, group homes, medical clinics, atypical residences, etc.)	Report all individual test results and full test average values of influent and effluent sampling obtained throughout the testing period for the evaluation of reduction of: CBOD ₅ , TSS and O&G. Establish the treatment capacity of the product tested in pounds per day for CBOD ₅ .
Category 3 Black water component of residential sewage (such as composting and incinerating toilets).	Report test results on all required performance criteria according to the format prescribed in the NSF test protocol described in Table I.
Total Nitrogen Reduction in Categories 1 & 2 (Above)	Report test results on all required performance criteria according to the format prescribed in the test protocol described in Table I.

¹ Test results for BOD₅ may be submitted in lieu of test results for CBOD₅. In these cases numerical values for CBOD₅ will be determined using the following formula: (BOD₅ × 0.83 = CBOD₅).

² Supplemental bacteriological reduction technology must be tested for influent/effluent fecal coliform or *E. coli* per WAC 246-272A-0130 (bacteriological reduction testing protocol). Supplemental fecal coliform or *E. coli* reducing technologies will be rated for log base 10 removal of fecal coliform or *E. coli*. The lowest 30-day geometric mean will be used to rate reduction level. The highest monthly geometric mean for treatment technology fecal coliform or *E. coli* reduction will be used as the baseline value for review.

Table III

Product Performance Requirements for Proprietary Treatment Products							
Treatment Component/Sequence Category	Product Performance Requirements						
Category 1 Designed to treat effluent anticipated to be equal to or less than treatment level E.	Treatment System Performance Testing Levels						
		Parameters					
	Level	CBOD₅ mg/L	TSS mg/L	O&G mg/L	FC cfu/100 mL	TN mg/L	<i>E. coli</i> cfu/100 mL
	A	10	10	—	—	—	—
	B	15	15	—	—	—	—
	C	25	30	—	—	—	—
	BL1			—	200	—	126
	BL2	—	—	—	1,000	—	—
	BL3	—	—	—	50,000	—	—
	E	228	80	20	—	—	—
N	—	—	—	—	30 (or 50% reduction based on mass loading as required in WAC 246-272A-0320)	—	
Values for Levels A - C are 30-day values (averages for CBOD ₅ , TSS, and geometric mean for FC.) All 30-day averages throughout the test period must meet these values in order to be registered at these levels. Values for Levels E and N are derived from full test averages.							
Category 2 Designed to treat high-strength sewage when septic tank effluent is anticipated to be greater than treatment level E.	All of the following requirements must be met: (1) All full test averages must meet Level E; and (2) Establish the treatment capacity of the product tested in pounds per day for CBOD ₅ .						

Product Performance Requirements for Proprietary Treatment Products	
Treatment Component/Sequence Category	Product Performance Requirements
(Such as at restaurants, grocery stores, mini-marts, group homes, medical clinics, residences, etc.)	
Category 3 Black water component of residential sewage (such as composting and incinerating toilets).	Test results must meet the performance requirements established in the NSF test protocol.
Total Nitrogen Reduction in Categories 1 & 2 (Above)	Test results must establish product performance effluent quality meeting Level N, when presented as the full test average.

[Statutory Authority: RCW 43.20.50 [43.20.050]. WSR 25-06-036, s 246-272A-0110, filed 2/26/25, effective 4/1/25. Statutory Authority: RCW 43.20.050(3), 43.20.065, chapters 70A.105 and 70A.110 RCW. WSR 24-06-046, § 246-272A-0110, filed 3/1/24, effective 4/1/24. Statutory Authority: RCW 43.20.050. WSR 05-15-119, § 246-272A-0110, filed 7/18/05, effective 9/15/05.]

WAC 246-272A-0120 Proprietary treatment product registration—Process and requirements. (1) Manufacturers shall register proprietary treatment products with the department by submitting a complete registration application for review and approval in the format provided by the department, including:

(a) Manufacturer's name, mailing address, phone number, email address, and website address;

(b) Contact person's name, title, mailing address, email address, and phone number. The contact person must be vested with the authority to represent the manufacturer in this capacity;

(c) Name, including specific brand and model, of the proprietary treatment product;

(d) A description of the function of the proprietary treatment product along with any known limitation on the use of the product;

(e) Product description and technical information, including process flow drawings and schematics; materials and characteristics; component design specifications; design capacity, volumes and flow assumptions and calculations; components; dimensioned drawings and photos;

(f) For treatment systems in Category 2, daily capacity of the model or models in pounds per day of CBOD₅;

(g) Siting and installation requirements;

(h) Detailed description, procedure, and schedule of routine service and system maintenance events;

(i) Estimated operational costs for the first five years of the treatment component's life. This must include both estimated annual electricity costs, and routine maintenance costs, including replacement of parts;

(j) Identification of information subject to protection from disclosure of trade secrets;

(k) Most current dated copies of product brochures and manuals: *Sales & Promotional; Design; Installation; Operation & Maintenance; and Homeowner Instructions;*

(l) The most recently available product test protocol dated no earlier than the dates in WAC 246-272A-0110 Table I and the results report;

(m) A signed and dated certification by the manufacturer's agent specifically including the following statement, "I certify that I represent (INSERT MANUFACTURING COMPANY NAME) and I am authorized to prepare or direct the preparation of this application for registration. I attest, under penalty of law, that this document and all attachments are true, accurate, and complete. I understand and accept that the product testing results reported with this application for registration are the parameters and values to be used for determining conformance with Treatment System Performance Testing Levels established in chapter 246-272A WAC";

(n) A signed and dated certification from the testing entity including the statement, "I certify that I represent (INSERT TESTING ENTITY NAME), that I am authorized to report the testing results for this proprietary treatment product. I attest, under penalty of law, that the report about the test protocol and results is true, accurate, and complete"; and

(o) The fee described in WAC 246-272-2000.

(2) Products within a single series or model line, sharing distinct similarities in design, materials, and capacities, may be registered under a single application, consistent with the provisions of their test protocol for the certification of other products within a product series. Products outside of the series or model line must be registered under separate applications.

(3) Upon receipt of a registration application the department shall:

(a) Verify that the application is complete including dated and current copies of all of the required manuals; and

(b) If approved, place the product on the department's list of registered on-site treatment and distribution products.

(4) All registrations are valid for up to one year, expiring on December 31st of each year. Fees are not prorated.

(5) In order to renew a proprietary treatment product technology registration, a manufacturer shall:

(a) Apply for renewal of product registration using the format provided by the department;

(b) Submit any of the following applicable reports:

(i) A retesting report from the testing entity according to the protocol required for registration as identified in this section;

(ii) A field verification performance report as identified in the proprietary on-site wastewater treatment products DS&G, dated February 1, 2025. If field performance results demonstrate that the product has failed to meet the requirements in the DS&G, the manufacturer shall report to the department describing the reasons for the failure to meet the requirements consistent with the DS&G;

(c) Provide an attestation to the department verifying whether or not the product has changed over the previous year. If the product has changed, the attestation must also include a full description of the changes. If the product has changed in a way that affects performance, the product may not be renewed and shall meet the requirements for initial registration;

- (d) Provide a statement that all required dated manuals are current, or submit the updated and dated new manuals; and
- (e) Submit the fee established in WAC 246-272-2000.
- (6) As part of product registration renewal, the department shall:
 - (a) Request field assessment comments from local health officers no later than October 31st of each year. These comments may include concerns about a variety of field assessment issues, including:
 - (i) Product function, including verification of field performance testing as identified in the DS&G;
 - (ii) Product reliability; and
 - (iii) Problems arising with operation and maintenance;
 - (b) Discuss with the TAG any field assessment information that may impact product registration renewal;
 - (c) Notify the manufacturer of any product to be discussed with the TAG, prior to discussion with the TAG, regarding the nature of comments received;
 - (d) Renew the product registration unless:
 - (i) The manufacturer of a product does not apply for renewal; or
 - (ii) The department, after deliberation with the TAG, concludes product registration renewal should not be given or should be delayed until the manufacturer submits information that satisfactorily answers concerns and issues; and
 - (e) Provide a compliance plan to the manufacturer within 90 days based on departmental concerns of public health risk related to the product.
- (7) The department shall maintain a list of registered on-site treatment and distribution products meeting the registration requirements established in this chapter. The product registration is a condition of approval for use.
- (8) Manufacturers shall have readily accessible product information for designers, regulators, OSS owners and other interested parties posted on the manufacturer's website including the most current dated version of:
 - (a) Product manuals;
 - (b) Design instructions;
 - (c) Installation instructions;
 - (d) Operation and maintenance;
 - (e) Owner instructions; and
 - (f) How to locate a list of representatives and manufacturer certified maintenance service providers, if any.

[Statutory Authority: RCW 43.20.050(3), 43.20.065, chapters 70A.105 and 70A.110 RCW. WSR 24-06-046, § 246-272A-0120, filed 3/1/24, effective 4/1/25. Statutory Authority: RCW 43.20.050. WSR 05-15-119, § 246-272A-0120, filed 7/18/05, effective 9/15/05.]

WAC 246-272A-0130 Bacteriological reduction. This section establishes the requirements for registering bacteriological reduction processes.

- (1) Manufacturers shall, for the purpose of product registration as described in WAC 246-272A-0110 and 246-272A-0120:
 - (a) For meeting treatment level BL1, verify bacteriological reduction performance by sampling for fecal coliform or *E. coli*.
 - (b) For meeting treatment level BL2 or BL3, verify bacteriological reduction performance by sampling for fecal coliform.

(2) All test data submitted for product registration shall be produced by an ANSI accredited, third-party testing and certification organization whose accreditation is specific to on-site wastewater treatment products. Bacteriological reduction performance must be determined either:

(a) According to the procedures in NSF/ANSI 385 for supplemental bacteriological reduction; or

(b) Concurrent with testing protocol. The treatment product or treatment component sequence testing according to the NSF/ANSI 40 testing protocol.

(3) Testing under subsection (2)(b) of this section shall be completed in compliance with the following requirements:

(a) Collect samples from both the influent and effluent streams, identifying the treatment performance achieved by the full treatment process, component or sequence;

(b) Obtain influent characteristics falling within a range of 10^4 - 10^8 fecal coliform/100 mL or 10^2 - 10^6 *E. coli*/100 mL calculated as 30-day geometric means during the test;

(c) Test the influent to any disinfection unit and report the following at each occasion of sampling performed in (d) of this subsection:

(i) Flow rate;

(ii) pH;

(iii) Temperature;

(iv) Turbidity; and

(v) Color;

(d) Obtain samples for fecal coliform or *E. coli* analysis during both the design loading and stress loading periods identified by NSF/ANSI 40. Grab samples shall be collected from both the influent and effluent on three separate days of the week. Each set of influent and effluent grab samples must be taken from a different dosing time frame, either morning, afternoon, or evening, so that samples have been taken from each dosing time frame by the end of the week;

(e) Conduct analyses according to standard methods;

(f) Report the geometric mean of fecal coliform or *E. coli* test results from all samples taken within 30-day or monthly calendar periods;

(g) Report the individual results of all samples taken throughout the test period design and stress loading; and

(h) Report all maintenance and servicing conducted during the testing period, including for example, instances of cleaning a UV lamp, or replenishment of chlorine chemicals.

(4) Manufacturers may register products in treatment levels BL1 and BL2 using disinfection.

(5) Manufacturers may not register products for treatment level BL3 using disinfection.

[Statutory Authority: RCW 43.20.050(3), 43.20.065, chapters 70A.105 and 70A.110 RCW. WSR 24-06-046, § 246-272A-0130, filed 3/1/24, effective 4/1/25. Statutory Authority: RCW 43.20.050. WSR 06-01-020, § 246-272A-0130, filed 12/12/05, effective 1/12/06; WSR 05-15-119, § 246-272A-0130, filed 7/18/05, effective 9/15/05.]

WAC 246-272A-0140 Proprietary distribution products—Certification requirements. (1) Proprietary distribution products, including

gravelless distribution products and subsurface dripline products, must be registered with the department before permitting, sale, and use. To be eligible for registration as described in WAC 246-272A-0145, products must first be certified as described in this section.

(2) To be certified, proprietary gravelless distribution products must:

(a) Be constructed or manufactured from materials that are non-decaying and nondeteriorating and do not leach chemicals when exposed to sewage and the subsurface soil environment;

(b) Provide liquid storage volume at least equal to the storage volume provided within the 30 percent void space in a 12-inch layer of drainrock in a drainrock-filled distribution system. This storage volume must be established by the gravelless distribution products, OSS design and installation and must be maintained for the life of the OSS. This requirement may be met on a lineal-foot, or on an overall system design basis;

(c) Provide effluent distribution to the infiltrative surface at the soil interface; and

(d) Maintain the integrity of the trench or bed. The material used, by its nature and its manufacturer-prescribed installation procedure, must withstand the physical forces of the soil sidewalls, soil backfill, and the weight of equipment used in the backfilling.

(3) Proprietary subsurface dripline products shall:

(a) Be warranted by the manufacturer for use with sewage and for resistance to root intrusion;

(b) Incorporate emitters with a maximum nominal rated discharge of 1.3 gallons per hour. Emitter discharge rate may be controlled either by use of pressure-compensating emitters or with a pressure regulator; and

(c) Be color-coded purple to identify that the pipe contains non-potable water from a sewage source.

(4) To be certified by the department, the manufacturer must submit:

(a) A signed and dated statement by the manufacturer's agent specifically including the following statement, "I certify that I represent (INSERT MANUFACTURING COMPANY NAME) and I am authorized to prepare or direct the preparation of this application for product registration. I attest, under penalty of law, that this document and all attachments, are true, accurate, and complete."

(b) A signed and dated statement from the licensed professional engineer including the statement, "I certify that I represent (INSERT PROFESSIONAL ENGINEERING FIRM NAME), that I am authorized to certify the performance characteristics for the proprietary distribution product presented in this application. I attest, under penalty of law, that the technology report is true, accurate, and complete."

[Statutory Authority: RCW 43.20.050(3), 43.20.065, chapters 70A.105 and 70A.110 RCW. WSR 24-06-046, § 246-272A-0140, filed 3/1/24, effective 4/1/25. Statutory Authority: RCW 43.20.050. WSR 05-15-119, § 246-272A-0140, filed 7/18/05, effective 9/15/05.]

WAC 246-272A-0145 Proprietary distribution product registration
—Process and requirements. (1) Manufacturers shall register their proprietary distribution products with the department by submitting a

complete application for review and approval in the format provided by the department, including:

(a) Manufacturer's name, mailing address, phone number, email address, and website address;

(b) Contact person's name, title, mailing address, email address, and phone number. The contact person must be vested with the authority to represent the agent of the manufacturer in this capacity;

(c) Name, including specific brand and model, of the proprietary distribution product;

(d) A description of the function of the proprietary distribution product along with any known limitations on the use of the product;

(e) Product description and technical information, including schematics; materials and characteristics; component design specifications; design capacity, volumes and flow assumptions and calculations; components; dimensioned drawings and photos;

(f) Siting and installation requirements;

(g) Detailed description, procedure, and schedule of routine service and system maintenance events;

(h) Identification of information subject to protection from disclosure of trade secrets;

(i) Most current, dated copies of product brochures and manuals: *Sales & Promotional; Design; Installation; Operation & Maintenance; and Owner Instructions;*

(j) For gravelless chamber systems a quantitative description of the actual exposed trench-bottom infiltrative surface area for each model seeking registration;

(k) A statement from a professional engineer that certifies the technology meets the standards established in WAC 246-272A-0140;

(1) The fee established in WAC 246-272-2000.

(2) Products within a single series or model line, sharing distinct similarities in design, materials, and capacities, may be registered under a single application. Products outside of the series or model line must be registered under separate applications.

(3) Upon receipt of an application the department shall:

(a) Verify that the application is complete, including dated and current copies of all required manuals; and

(b) If approved, place the product on the list of registered on-site treatment and distribution products.

(4) All registrations are valid for up to one year, expiring on December 31st of each year. Required fees are not prorated.

(5) In order to renew a proprietary distribution product registration, a manufacturer shall:

(a) Apply for renewal of product registration using the form or in the format provided by the department;

(b) Provide an attestation to the department verifying whether or not the product has changed over the previous year. If the product has changed, the attestation must also include a full description of the changes. If the product has changed in a way that affects performance, the product may not be renewed and shall meet the requirements of initial registration;

(c) Provide a statement that all required dated manuals are current, or submit the updated and dated new manuals; and

(d) Submit the fee established in WAC 246-272-2000.

(6) As part of product registration renewal, the department will:

(a) Request field assessment comments from local health officers before November 1st of each year. These comments may include concerns about a variety of field assessment issues, including product func-

tion, product reliability, and problems arising with operation and maintenance;

(b) Discuss with the TAG any field assessment information that may impact product registration renewal;

(c) Notify the manufacturer of any product to be discussed with the TAG, prior to discussion with the TAG, regarding the nature of comments received;

(d) Renew the product registration unless:

(i) The manufacturer of a product does not apply for renewal; or

(ii) The department, after deliberation with the TAG, concludes product registration renewal should not be given or should be delayed until the manufacturer submits information that satisfactorily answers concerns and issues; and

(e) Provide a compliance plan to the manufacturer within 90 days based on departmental concerns of public health risk related to the product.

(7) The department shall maintain a list of proprietary distribution products meeting the registration requirements established in this chapter. The product registration is a condition of approval for use.

(8) Manufacturers shall have readily accessible product information for designers, regulators, OSS owners and other interested parties posted on the manufacturer's website including the most current dated version of:

(a) Product manuals;

(b) Design instructions;

(c) Installation instructions;

(d) Operation and maintenance;

(e) Owner instructions; and

(f) How to locate a list of representatives and manufacturer certified maintenance service providers, if any.

[Statutory Authority: RCW 43.20.050(3), 43.20.065, chapters 70A.105 and 70A.110 RCW. WSR 24-06-046, § 246-272A-0145, filed 3/1/24, effective 4/1/25. Statutory Authority: RCW 43.20.050. WSR 05-15-119, § 246-272A-0145, filed 7/18/05, effective 9/15/05.]

WAC 246-272A-0170 Product development permits. (1) A local health officer may issue a PDP for any proprietary treatment component or sequence to be used during a development period. To protect public health during the development period, a complete OSS meeting the requirements of this chapter and the site must already be installed. The component or sequence under development may then be added to the treatment system allowing the developer to gather data about performance in the field. The PDP allows developers to explore new technologies prior to product testing and registration under WAC 246-272A-0110 and 246-272A-0120. The PDP is not an alternative to testing and registration.

(2) An applicant for a PDP must submit an application to the local health officer including all of the following:

(a) Proof of an existing conforming OSS in compliance with all local requirements, or a permit for a conforming OSS. The conforming OSS must be installed in its entirety before the PDP becomes valid;

(b) A description of the product under development including performance goals and a description of how the system will be used to treat sewage;

(c) Financial assurance covering the correction of any potential public health threats or environmental damage resulting from the use of the product under development. Instruments of financial assurance include:

(i) An irrevocable letter of credit in the amount required by the local health officer issued by an entity authorized to issue letters of credit in Washington state;

(ii) Cash or security deposit payable to the local health jurisdiction in the amount required by the local health officer; or

(iii) Any other financial assurance that satisfies the local health officer.

(d) Documentation signed by the owner of the proposed product development site allowing access to the local health officer for inspection of the site; and

(e) Any other information required by the local health officer.

(3) The local health officer may impose additional requirements for a PDP necessary to safeguard the performance of the conforming OSS, including providing performance data to the local health officer.

(4) A PDP is a site-specific permit. Product development at multiple sites requires a PDP for each site.

(5) During the term of the PDP, product development, testing and sampling are under the full control of the product developer and all data collected is considered proprietary information.

(6) A PDP is valid for one year and may be renewed by the local health officer.

(7) The product development period is over when the original PDP or any subsequently renewed permits have expired. At this time, the product developer:

(a) Shall, at the direction of the local health officer, remove the product under development from the site, reestablishing all appropriate plumbing and power connections for the conforming OSS.

(b) May subject the product to performance testing described in WAC 246-272A-0110 to allow the product to be eligible for registration with the department.

(8) The local health officer may revoke or amend a PDP:

(a) If the continued operation or presence of the product under development:

(i) Presents a risk to public health or the environment;

(ii) Causes adverse effects on the proper function of the conforming OSS on the site; or

(iii) Leaks or discharges sewage on the surface of the ground.

(b) If the developer fails to comply with any requirements stipulated on the permit by the local health officer.

(9) The local health officer may charge fees adequate to administer the PDP program.

[Statutory Authority: RCW 43.20.050(3), 43.20.065, chapters 70A.105 and 70A.110 RCW. WSR 24-06-046, § 246-272A-0170, filed 3/1/24, effective 4/1/25. Statutory Authority: RCW 43.20.050. WSR 05-15-119, § 246-272A-0170, filed 7/18/05, effective 7/1/07.]

SPECIFIC REQUIREMENTS

WAC 246-272A-0200 Permit requirements. (1) A permit is not required for a minor repair. The local health officer may require the

owner to submit information regarding any activities defined as a minor repair for recordkeeping purposes.

(2) Except for a minor repair, a person proposing the installation, repair, modification, connection to, or expansion of an OSS, shall submit an application and obtain a permit from the local health officer prior to beginning construction. The permit application must include the following:

(a) General information including:

(i) Name and address of the property owner and the applicant at the head of each page of the submission;

(ii) Parcel number and if available, the address of the site;

(iii) Source of drinking water supply;

(iv) Identification if the property is within the boundaries of a recognized sewer utility;

(v) Size of the parcel;

(vi) Type of permit for which application is being made. For example, new installation, repair, expansion, modification, or operational;

(vii) Source of sewage. For example, residence, restaurant, or other type of business;

(viii) Location of utilities;

(ix) Name of the site evaluator;

(x) Name, signature and stamp of the designer;

(xi) Date of application; and

(xii) Name and signature of the fee simple owner, the contract purchaser of the property, or the owner's authorized agent.

(b) The soil and site evaluation as specified under WAC 246-272A-0220;

(c) A dimensioned site plan of the proposed initial OSS, the reserve area and those areas immediately adjacent that contain characteristics impacting design including:

(i) Designated areas for the proposed initial OSS and the reserve area;

(ii) The location of all soil logs and other soil tests for the OSS;

(iii) General topography and slope;

(iv) Drainage characteristics;

(v) Horizontal separations as noted in Table IV in WAC 246-272-0210;

(vi) The location of existing and proposed encumbrances affecting OSS placement, including legal access documents if any component of the OSS is not on the lot where the sewage is generated;

(vii) An arrow indicating north;

(viii) A legend of symbols used;

(ix) Plan scale and a graphic scale bar;

(x) Vertical datum used (such as "assumed," "North American Vertical Datum of 1988 (NAVD 88)," "National Shoreline Reference Station (NSRS)," or "unknown");

(xi) An elevation benchmark and relative elevations of system components;

(xii) Name, signature, stamp, and contact information of the designer; and

(xiii) A statement on limitation of use indicating the site plan is not a survey.

(d) A detailed OSS design meeting the requirements under WAC 246-272A-0230, 246-272A-0232, 246-272A-0234, and 246-272A-0238 including:

- (i) A drawing showing the dimensioned location of components of the proposed OSS, and the system designed for the reserve area if reserve site characteristics differ significantly from the initial area;
- (ii) Vertical cross-section drawings showing:
 - (A) The depth of the soil dispersal component, the vertical separation, and depth of cover material; and
 - (B) Other new OSS components constructed at the site.
- (iii) Calculations and assumptions supporting the proposed design, including:
 - (A) System operating capacity and design flow;
 - (B) Soil type;
 - (C) Hydraulic loading rate in the soil dispersal component; and
 - (e) Any additional information as deemed necessary by the local health officer.
- (3) The local health officer may develop the information required in subsection (2) of this section if authorized by local rules.
- (4) The local health officer shall:
 - (a) Respond to an application within 30 days as required in RCW 70.05.074;
 - (b) Permit only public domain treatment technologies that are described in this chapter or in a current DS&G;
 - (c) Permit only proprietary products that are registered by the department;
 - (d) Issue a permit when the information submitted under subsection (2) of this section meets the requirements contained in this chapter and in local rules;
 - (e) Identify the permit as a new installation, repair, expansion, modification, or operational permit;
 - (f) Specify the expiration date on the permit. The expiration date may not exceed five years from the date of permit issuance;
 - (g) Include a reminder on the permit application of the applicant's right of appeal; and
 - (h) If requiring an operational permit, state the period of validity and the date and conditions of renewal including any required field compliance.
- (5) The local health officer may revoke or deny a permit for just cause. Examples include, but are not limited to:
 - (a) Construction or continued use of an OSS that threatens public health;
 - (b) Misrepresentation or concealment of material fact in information submitted to the local health officer; or
 - (c) Noncompliance with the conditions of the permit, this chapter or any local rules.
- (6) An applicant for a permit to install an OSS serving more than one development must submit an application that proves the OSS:
 - (a) Is owned or managed in perpetuity by a public entity;
 - (b) Is described in a separate writing including, but not limited to, an easement, covenant, contract, or other legal document authorizing access for construction, operation maintenance, and repair; and
 - (c) If owned privately, is adequately financed.
- (7) The local health officer shall not delegate the authority to issue permits.
- (8) The local health officer may stipulate additional requirements for a particular permit if necessary to protect public health.

[Statutory Authority: RCW 43.20.050(3), 43.20.065, chapters 70A.105 and 70A.110 RCW. WSR 24-06-046, § 246-272A-0200, filed 3/1/24, effective]

tive 4/1/25. Statutory Authority: RCW 43.20.050. WSR 05-15-119, § 246-272A-0200, filed 7/18/05, effective 7/1/07.]

WAC 246-272A-0210 Location. (1) OSS must be designed and installed to meet at least the minimum horizontal separations shown in Table IV:

**Table IV
Minimum Horizontal Separations**

Items Requiring Setback	From edge of soil dispersal component and reserve area	From sewage tank and distribution box	From building sewer, and nonperforated distribution pipe
Well	100 ft.	50 ft.	50 ft.
Public drinking water well	100 ft.	100 ft.	100 ft.
Nonpublic drinking water well	100 ft.	50 ft.	50 ft.
Public drinking water spring or surface water measured from the ordinary high-water mark	200 ft.	200 ft.	100 ft.
Nonpublic drinking water spring or surface water measured from the ordinary high-water mark ¹	100 ft.	50 ft.	50 ft.
Nonpublic, in-ground, drinking water containment vessel ³	20 ft.	10 ft.	10 ft.
Pressurized water supply line or easement for water supply line	10 ft.	10 ft.	10 ft.
Closed geothermal loop ⁴ or pressurized nonpotable water line	10 ft.	10 ft.	10 ft.
Decommissioned well (decommissioned in accordance with chapter 173-160 WAC)	10 ft.	N/A	N/A
Surface water measured from the ordinary high-water mark	100 ft.	50 ft.	10 ft.
Building foundation/in-ground swimming pool	10 ft.	5 ft.	2 ft.
Property or easement line	5 ft.	5 ft.	N/A
Lined ⁵ stormwater detention pond ⁶			
Down-gradient ⁷ :	30 ft.	N/A	N/A
Up-gradient ⁷ :	10 ft.	N/A	N/A
Unlined ⁸ stormwater infiltration pond ⁶ (up or down-gradient) ⁷	100 ft.	50 ft.	10 ft.
Irrigation canal or irrigation pond (up or down-gradient)	100 ft.	50 ft.	10 ft.
Interceptor/curtain drains/foundation drains/drainage ditches			
Down-gradient ² :	30 ft.	5 ft.	N/A
Up-gradient ² :	10 ft.	N/A	N/A
Subsurface stormwater infiltration or dispersion component ⁶			
Down-gradient ⁷ :	30 ft.	10 ft.	N/A
Up-gradient ⁷ :	30 ft.	10 ft.	N/A
Other site features that may allow effluent to surface			
Down-gradient ² :	30 ft.	5 ft.	N/A
Up-gradient ² :	10 ft.	N/A	N/A

Items Requiring Setback	From edge of soil dispersal component and reserve area	From sewage tank and distribution box	From building sewer, and nonperforated distribution pipe
Down-gradient cuts or banks with at least 5 ft. of original, undisturbed soil above a restrictive layer due to a structural or textural change	25 ft.	N/A	N/A
Down-gradient cuts or banks with less than 5 ft. of original, undisturbed soil above a restrictive layer due to a structural or textural change	50 ft.	N/A	N/A
Soil dispersal components serving a separate OSS	10 ft.	N/A	N/A

- 1 If surface water is used as a public drinking water supply, the designer shall locate the OSS outside of the required source water protection area.
- 2 The item is down-gradient when liquid will flow toward it upon encountering a water table or a restrictive layer. The item is up-gradient when liquid will flow away from it upon encountering a water table or restrictive layer.
- 3 Any in-ground containment vessel used to store drinking water.
- 4 A network of underground piping carrying fluid under pressure used to heat and cool a structure.
- 5 Lined means any component that has the intended function of detaining the stormwater with no intention of dispersal into surrounding soil.
- 6 OSS components take precedence in cases of horizontal setback conflicts between OSS and stormwater components.
- 7 Down-gradient means that subsurface water flows toward and is usually located lower in elevation. Up-gradient means subsurface water does not flow toward and generally flat, or flows away from and generally located higher in elevation.
- 8 Unlined means any component that has the ability to or intended function of infiltrating the stormwater.

(2) When conditions indicate a greater potential for contamination or pollution, the local health officer may increase the minimum horizontal separations. Examples of such conditions include, but are not limited to, excessively permeable soils, unconfined aquifers, shallow or saturated soils, dug wells, and improperly abandoned wells.

(3) The local health officer may allow a reduced horizontal separation to not less than two feet from where the property line, easement line, or building foundation is up-gradient.

(4) The local health officer may require an applicant to demonstrate the OSS meets (a), (b), or (c) of this subsection when determining if a horizontal separation to a minimum of 75 feet between an OSS dispersal component and a water well, spring, or surface water that is not a public water source is allowed:

(a) Adequate protective site-specific conditions, such as physical settings with low hydrogeologic susceptibility from contaminant infiltration. Examples of such conditions include evidence of confining layers, an aquatard that separates potable water from the OSS treatment zone, excessive depth to groundwater, down-gradient contaminant source, or outside the zone of influence; or

(b) Design and proper operation of an OSS with enhanced treatment performance beyond that accomplished by meeting the vertical separation and effluent distribution requirements described in Table VI in WAC 246-272A-0230; or

(c) Evidence the OSS satisfies the requirements of (a) and (b) of this subsection.

(5) Persons shall design or install a soil dispersal component only if:

(a) The slope is less than 45 percent or 24 degrees;

(b) The area is not subject to:

(i) Encroachment by buildings or construction such as placement of power poles and underground utilities;

(ii) Cover by impervious material;

(iii) Vehicular traffic; or

(iv) Other activities adversely affecting the soil or the performance of the OSS.

(c) Sufficient reserve area for replacement exists to treat and dispose one hundred percent of the design flow;

- (d) The land is stable; and
- (e) Surface drainage is directed away from the site.

(6) The local health officer may approve a sewer transport line within ten feet of a water supply line if the sewer line is constructed in accordance with section C1-9.1 of the department of ecology's "Criteria For Sewage Works Design," 2008.

[Statutory Authority: RCW 43.20.050(3), 43.20.065, chapters 70A.105 and 70A.110 RCW. WSR 24-06-046, § 246-272A-0210, filed 3/1/24, effective 4/1/25. Statutory Authority: RCW 43.20.050. WSR 05-15-119, § 246-272A-0210, filed 7/18/05, effective 7/1/07.]

WAC 246-272A-0220 Soil and site evaluation. (1) Only professional engineers, designers, or local health officers may perform soil and site evaluations. Soil scientists may only perform soil evaluations.

(2) The person evaluating the soil and site shall:

(a) Report:

(i) A sufficient number of soil logs to evaluate conditions within:

- (A) The initial soil dispersal component; and
- (B) The reserve area.

(ii) The groundwater conditions, the date of the observation, and the probable maximum height;

(iii) The topography of the proposed initial OSS, the reserve area, and those areas immediately adjacent that contain characteristics impacting the design;

(iv) The drainage characteristics of the proposed initial OSS, the reserve area and those areas immediately adjacent that contain characteristics impacting the design;

(v) The existence of structurally deficient soils subject to major wind or water erosion events such as slide zones and dunes;

(vi) The existence of designated flood plains;

(vii) Other areas identified in the local management plan required in WAC 246-272A-0015; and

(viii) The location of existing features affecting OSS placement, such as, but not limited to:

- (A) Wells;
- (B) Water sources and supply lines;
- (C) Surface water and stormwater infiltration areas;
- (D) Abandoned wells;
- (E) Outcrops of bedrock and restrictive layers;
- (F) Buildings;
- (G) Property lines and lines of easement;
- (H) Interceptors such as footing drains, curtain drains, and drainage ditches;
- (I) Cuts, banks, and fills;
- (J) Driveways and parking areas;
- (K) Existing OSS; and
- (L) Underground utilities;

(b) Use the soil and site evaluation procedures and terminology in accordance with Chapter 5 of the *On-site Wastewater Treatment Systems Manual*, EPA 625/R-00/008, February 2002 except where modified by, or in conflict with, this chapter;

(c) Use the soil names and particle size limits of the United States Department of Agriculture Natural Resources Conservation Service classification system;

(d) Determine texture, structure, compaction, and other soil characteristics that affect the treatment and water movement potential of the soil by using normal field or laboratory procedures such as particle size analysis; and

(e) Classify the soil as in Table V:

Table V
Soil Type Descriptions

Soil Type	Soil Textural Classifications
1	Gravelly and very gravelly coarse sands, all extremely gravelly soils excluding those with soil types 5 and 6 as the nongravel portion, and all soil types with greater than or equal to 90% rock fragments.
2	Coarse sands.
3	Medium sands, loamy coarse sands, loamy medium sands.
4	Fine sands, loamy fine sands, sandy loams, loams.
5	Very fine sands, loamy very fine sands; or silt loams, sandy clay loams, clay loams and silty clay loams with a moderate or strong structure (excluding platy structure).
6	Other silt loams, sandy clay loams, clay loams, silty clay loams.
7 Unsuitable for treatment or dispersal	Sandy clay, clay, silty clay, strongly cemented or firm soils, soil with a moderate or strong platy structure, any soil with a massive structure, any soil with appreciable amounts of expanding clays.

(3) The owner of the property or the owner's agent shall:

(a) Prepare the soil log excavation to:

(i) Allow examination of the soil profile in its original position by:

(A) Excavating pits of sufficient dimensions to enable observation of soil characteristics by visual and tactile means to a depth three feet deeper than the anticipated infiltrative surface at the bottom of the soil dispersal component; or

(B) Stopping at a shallower depth if a water table or restrictive layer is encountered;

(ii) Allow determination of the soil's texture, structure, color, bulk density or compaction, water absorption capabilities or permeability, and elevation of the highest seasonal water table; and

(b) Assume responsibility for constructing and maintaining the soil log excavation in a manner to prevent injury as required by chapter 296-155 WAC.

(4) The local health officer:

(a) Shall render a decision on the height of the water table within 12 months of receiving the application under precipitation conditions typical for the region;

(b) May require water table measurements to be recorded during months of probable high-water table conditions, if insufficient information is available to determine the highest seasonal water table;

(c) May require any other soil and site information affecting location, design, or installation;

(d) May reduce the required number of soil logs for OSS serving a single-family residence if adequate soils information has previously been developed; and

(e) May require another site and soil evaluation if the site has been altered since the initial site and soil evaluation was submitted to the local health officer.

[Statutory Authority: RCW 43.20.050(3), 43.20.065, chapters 70A.105 and 70A.110 RCW. WSR 24-06-046, § 246-272A-0220, filed 3/1/24, effective 4/1/25. Statutory Authority: RCW 43.20.050. WSR 05-15-119, § 246-272A-0220, filed 7/18/05, effective 7/1/07.]

WAC 246-272A-0230 Design requirements—General. (1) OSS must only be designed by a professional engineer, licensed under chapter 18.43 RCW, or an OSS designer, licensed under chapter 18.210 RCW, except:

(a) If at the discretion of the local health officer, a resident owner of a single-family residence not within 200 feet of a marine shoreline is allowed to design an OSS for that residence; or

(b) If the local health officer performs the soil and site evaluation, the health officer may design the OSS.

(2) The designer shall use the following criteria when developing a design for an OSS:

(a) All sewage from the building served is directed to the OSS;

(b) Sewage tanks are in compliance with chapter 246-272C WAC;

(c) Drainage from the surface, footing drains, roof drains, sub-surface stormwater infiltration systems, and other nonsewage drains is prevented from entering the OSS, the area where the OSS is located, and the reserve area;

(d) The OSS is designed to treat and disperse the sewage volume as follows:

(i) For single-family residences:

(A) The operating capacity is based on 45 gpd per capita with two people per bedroom;

(B) The minimum design flow per bedroom per day is the operating capacity of 90 gallons multiplied by 1.33 to account for a 33 percent surge capacity. This results in a minimum design flow of 120 gallons per bedroom per day;

(C) The local health officer may require a factor greater than 33 percent to account for surge capacity;

(D) The minimum design flow of the OSS is 240 gpd; and

(E) The local health officer may require an increase of the design flow for dwellings with anticipated greater flows, such as larger dwellings; or

(ii) For single-family residences with one additional dwelling served by the same OSS:

(A) All requirements in (d)(i) of this subsection apply;

- (B) The minimum design flow for one additional dwelling is 120 gallons per bedroom; and
- (C) The local health officer may require an increase of the design flow for dwellings with anticipated greater flows; or
 - (iii) For three or more dwellings served by the same OSS:
 - (A) All requirements in (d)(i) of this subsection apply;
 - (B) The minimum design flow for the first dwelling is 240 gallons per day;
 - (C) The minimum design flow for each additional dwelling is 120 gallons per bedroom;
 - (D) The local health officer may require an increase of the design flow for dwellings with anticipated greater flows; and
 - (E) The local health officer shall require documentation including, but not limited to, an easement, covenant, contract, or other legal document authorizing access for construction, operation, maintenance, and repair; or
 - (iv) For other facilities, the design flows noted in "On-site Wastewater Treatment Systems Manual," USEPA, EPA-625/R-00/008, February 2002 must be used. Sewage flows from other sources of information may be used in determining system design flows if they incorporate both an operating capacity and a surge capacity;
 - (e) The OSS is designed to address sewage quality as follows:
 - (i) For all systems, the designer shall consider:
 - (A) CBOD₅, TSS, and O&G;
 - (B) Other parameters that can adversely affect treatment anywhere along the treatment component sequence. Examples include pH, temperature, and dissolved oxygen;
 - (C) The sensitivity of the site where the OSS will be installed. Examples include areas where fecal coliform constituents can result in public health concerns, such as shellfish growing areas, designated swimming areas, and other areas identified by the local management plan required in WAC 246-272A-0015; and
 - (D) Nitrogen contributions. Where nitrogen has been identified as a contaminant of concern by the local management plan required in WAC 246-272A-0015, it must be addressed through lot size, treatment, or both.
 - (ii) For OSS treating sewage from a nonresidential source, the designer shall provide the following information showing:
 - (A) The sewage is not industrial wastewater;
 - (B) The sewage effluent quality and identifying chemicals found in the sewage effluent are not found in sewage effluent from a residential source; and
 - (C) A site-specific design providing the necessary treatment equaling required treatment of sewage effluent quality from a residential source;
 - (f) The vertical separation used to establish the treatment levels and application rates. The selected vertical separation must be used consistently throughout the design process; and
 - (g) Treatment levels:
 - (i) Requirements for matching treatment component and method of distribution with soil conditions of the soil dispersal component are listed in Table VI of this section. The treatment levels correspond with those established for treatment components under the product performance testing requirements in Table III of WAC 246-272A-0110. The method of distribution applies to the soil dispersal component.
 - (ii) Disinfection may not be used;

- (A) To achieve BL1 or BL2 in type 1 soils; or
- (B) BL3.

**Table VI
Treatment Component Performance Levels and
Method of Distribution¹**

Vertical Separation in inches	Soil Type		
	1	2	3-6
12 < 18	A & BL1 - pressure with timed dosing	B & BL2 - pressure with timed dosing	B & BL2 - pressure with timed dosing
≥18 < 24	B & BL2 - pressure with timed dosing	C & BL3 - pressure with timed dosing	C & BL3 - pressure with timed dosing
≥24 < 36	B & BL2 - pressure with timed dosing	C & BL3 - pressure with timed dosing	E - pressure with timed dosing
≥36 < 60	B & BL2 - pressure with timed dosing	E - pressure	E - gravity
≥60	C & BL2 - pressure	E - gravity	E - gravity

¹ The treatment component performance levels correspond with those established for treatment components under the product testing requirements in WAC 246-272A-0110.

(3) The coarsest textured soil within the vertical separation selected by the designer determines the minimum treatment level and method of distribution.

(4) The local health officer shall not approve designs for:

- (a) Cesspools; or
- (b) Seepage pits.

(5) The local health officer may approve a design for the reserve area different from the design approved for the initial OSS, if both designs meet the requirements of this chapter for new construction.

[Statutory Authority: RCW 43.20.050(3), 43.20.065, chapters 70A.105 and 70A.110 RCW. WSR 24-06-046, § 246-272A-0230, filed 3/1/24, effective 4/1/25. Statutory Authority: RCW 43.20.050. WSR 05-15-119, § 246-272A-0230, filed 7/18/05, effective 7/1/07.]

WAC 246-272A-0232 Design requirements—Septic tank sizing. Septic tanks must:

(1) Have at least two compartments with the first compartment liquid volume equal to one-half to two-thirds of the total liquid volume. This standard may be met by one tank with two compartments or by two single compartment tanks in series.

(2) Have the following minimum liquid volumes:

- (a) For a single-family residence use Table VII:

**Table VII
Required Minimum Liquid Volumes of Septic
Tanks**

Number of Bedrooms	Required Minimum Liquid Tank Volume in Gallons
≤4	1,000
Each additional bedroom	250

(b) For OSS treating sewage from a residential source, other than one single-family residence, 250 gallons per bedroom with a minimum of 1,000 gallons;

(c) For OSS treating sewage from a nonresidential source, three times the design flow.

(3) Comply with chapter 246-272C WAC.

[Statutory Authority: RCW 43.20.050(3), 43.20.065, chapters 70A.105 and 70A.110 RCW. WSR 24-06-046, § 246-272A-0232, filed 3/1/24, effective 4/1/25. Statutory Authority: RCW 43.20.050. WSR 05-15-119, § 246-272A-0232, filed 7/18/05, effective 7/1/07.]

WAC 246-272A-0233 Design requirements—Pump chambers. (1) All pump chambers, except pump basins, must be designed to meet the following requirements:

(a) Have a minimum volume of 1,000 gallons;

(b) Provide an internal volume to account for the design flow, full-time pump submergence, space for sludge accumulation below the pump inlet and emergency storage volume of at least 75 percent of the design flow;

(c) Follow any applicable DS&G or proprietary product design manual for all OSS components included in the pump chamber; and

(d) Comply with chapter 246-272C WAC.

(2) For the purposes of this section, "pump basin" means a water-tight receptacle that contains a pump to convey sewage from a limited use area that is separate from the main wastewater sewer pipe leaving a structure, to the main treatment component of an OSS; typically much smaller than a pump chamber and separate from the main sewer pipe due to elevation restrictions. Pump basins are intended for limited, specialized uses, and not intended as a replacement or substitute for a pump chamber. Pump basins must be in compliance with chapter 246-272C WAC.

[Statutory Authority: RCW 43.20.050(3), 43.20.065, chapters 70A.105 and 70A.110 RCW. WSR 24-06-046, § 246-272A-0233, filed 3/1/24, effective 4/1/25.]

WAC 246-272A-0234 Design requirements—Soil dispersal components. (1) All soil dispersal components, except one using a subsurface dripline product, must be designed to meet the following requirements:

(a) Maximum hydraulic loading rates described in Table VIII.

**Table VIII
Maximum Hydraulic Loading Rate**

		Column A	Column B
Soil Type	Soil Textural Classification Description	Loading Rate for Residential Septic Tank Effluent Using Gravity or Pressure Distribution gal./sq. ft./day	Loading Rate for Residential Effluent Meeting Treatment Level C & BL3 or Higher Effluent Quality Using Pressure Distribution gal./sq. ft./day
1	Gravelly and very gravelly coarse sands, all extremely gravelly soils excluding those with soil types 5 & 6 as the nongravel portion, all soil types with greater than or equal to 90% rock fragments.	1.0	1.2
2	Coarse sands.	1.0	1.2
3	Medium sands, loamy coarse sands, loamy medium sands.	0.8	1.0
4	Fine sands, loamy fine sands, sandy loams, loams.	0.6	0.8
5	Very fine sands, loamy very fine sands; or silt loams, sandy clay loams, clay loams and silty clay loams with a moderate structure or strong structure (excluding a platy structure).	0.4	0.56
6	Other silt loams, sandy clay loams, clay loams, silty clay loams.	0.2	0.2
7	Sandy clay, clay, silty clay and strongly cemented firm soils, soil with a moderate or strong platy structure, any soil with a massive structure, any soil with appreciable amounts of expanding clays.	Unsuitable	Unsuitable

(b) Calculation of the absorption area is based on:

(i) The design flow in WAC 246-272A-0230(2); and

(ii) Loading rates equal to or less than those in Table VIII of this section as applied to the infiltrative surface of the soil dispersal component or the finest textured soil within the vertical separation selected by the designer, whichever has the finest texture.

(c) Requirements for the method of distribution must correspond to those in WAC 246-272A-0230, Table VI.

(d) Soil dispersal components having daily design flow between 1,000 and 3,500 gallons of sewage per day must:

(i) Only be located in soil types 1-5;

(ii) Only be located on slopes of less than 30 percent, or 17 degrees; and

(iii) Have pressure distribution including time dosing.

(2) The local health officer may allow the maximum hydraulic loading rates in Table VIII of this section. Loading rates identified in Column B must not be combined with any dispersal component size reductions.

(3) All soil dispersal components using a subsurface dripline product must be designed to meet the following requirements:

(a) The absorption area calculation is based on:

(i) The design flow in WAC 246-272A-0230(2); and

(ii) Loading rates dependent on the soil type, other soil and site characteristics, and the spacing of dripline and emitters as directed in Table VIII of this section;

(b) A minimum installation of six inches into original, undisturbed soil;

(c) Timed dosing; and

(d) Daily design flows greater than 1,000 gallons of sewage per day:

(i) Located only in soil types 1-5;

(ii) Located only on slopes of less than 30 percent, or 17 degrees.

(4) All SSAS must meet the following requirements:

(a) The infiltrative surface may not be deeper than three feet below the finished grade, except under special conditions approved by the local health officer. The depth of such system must not exceed 10 feet from the finished grade;

(b) A minimum of six inches of sidewall must be located in suitable soil;

(c) Beds are only designed in soil types 1, 2, 3 or in fine sands with a width not exceeding 10 feet. Gravity beds must have a minimum of one lateral for every three feet in width;

(d) Individual laterals greater than 100 feet in length must use pressure distribution;

(e) A layer of between six and 24 inches of cover material; and

(f) Other features must conform with the "On-site Wastewater Treatment Systems Manual," United States Environmental Protection Agency EPA-625/R-00/008 February 2002 except where modified by, or in conflict with this section or local rules.

(5) SSAS with drainrock and distribution pipe must meet the following requirements:

(a) A minimum of two inches of drainrock above the distribution pipe;

(b) A minimum of six inches of drainrock below the distribution pipe; and

(c) Location of the sidewall below the invert of the distribution pipe in original undisturbed soil.

(6) The local health officer may allow the infiltrative surface area in a SSAS to include six inches of the SSAS sidewall height when meeting the required absorption area where total recharge by annual precipitation and irrigation is less than 12 inches per year.

(7) The local health officer may permit OSS consisting of septic tanks and a gravity SSAS in soil type 1 if all the following criteria are met:

(a) The OSS serves a single-family residence;

(b) The lot size is two and one-half acres or larger;

(c) Annual precipitation in the region is less than 25 inches per year from a reputable source approved by the local health officer;

(d) The OSS is located outside the 12 counties bordering Puget Sound; and

(e) The geologic conditions beneath the dispersal component must satisfy the minimum unsaturated depth requirements to groundwater as determined by the local health officer. The method for determination is described by "Design Guideline for Gravity Systems in Soil Type 1," 2017.

(8) Both the primary and reserve areas must be sized at least 100 percent of the approved loading rates. The local health officer may require the sizing of the reserve area using the loading rate in Table

VIII of this section. Column A must be used when sizing the primary area using Column B.

[Statutory Authority: RCW 43.20.050(3), 43.20.065, chapters 70A.105 and 70A.110 RCW. WSR 24-06-046, § 246-272A-0234, filed 3/1/24, effective 4/1/25. Statutory Authority: RCW 43.20.050. WSR 05-15-119, § 246-272A-0234, filed 7/18/05, effective 7/1/07.]

WAC 246-272A-0238 Design requirements—Facilitate operation, monitoring and maintenance. (1) The OSS must be designed to facilitate routine operation, monitoring, and maintenance according to the following criteria:

(a) For gravity OSS:

(i) Sewage tank access for maintenance and inspection at finished grade is required. The local health officer may allow access for maintenance and inspection of a sewage tank to be a maximum of six inches below finished grade provided a marker showing the location of the tank access is installed at finished grade.

(ii) Each SSAS lateral must include at least one observation port installed in a representative location in order to facilitate SSAS monitoring.

(b) For all other OSS, service access and monitoring ports at finished grade are required for all system components. Specific component requirements include:

(i) Septic tanks must have service access maintenance holes (formerly manholes) and monitoring ports for the inlet and outlet;

(ii) Surge, flow equalization or other sewage tanks must have service access maintenance holes;

(iii) Other pretreatment units such as aerobic treatment units and packed-bed filters must have service access maintenance holes and monitoring ports;

(iv) Pump chambers, tanks, and vaults must have service access maintenance holes;

(v) Disinfection units must have service access and be installed to facilitate complete maintenance and cleaning, including an easy-access, freefall sampling port; and

(vi) Soil dispersal components, excluding subsurface drip, must have monitoring ports for both distribution devices and the infiltrative surface.

(c) For systems using pumps, clearly accessible controls and warning devices are required including:

(i) Process controls such as floats, pressure activated pump on/off switches, and pump-run timers;

(ii) Diagnostic tools including dose cycle counters and hour meters on the sewage stream, or flow meters on either the water supply or sewage stream; and

(iii) Audible and visual alarms designed to alert a resident of a malfunction. The alarm must be placed on a circuit independent of the pump circuit.

(2) All accesses must be designed to allow for monitoring and maintenance and shall be secured to minimize injury or unauthorized access in a manner approved by the local health officer.

[Statutory Authority: RCW 43.20.050(3), 43.20.065, chapters 70A.105 and 70A.110 RCW. WSR 24-06-046, § 246-272A-0238, filed 3/1/24, effective

tive 4/1/25. Statutory Authority: RCW 43.20.050. WSR 05-15-119, § 246-272A-0238, filed 7/18/05, effective 7/1/07.]

WAC 246-272A-0240 Holding tank sewage systems. (1) A person may not install or use holding tank sewage systems for residential development or expansion of residences, whether seasonal or year-round, except as set forth under subsection (2) of this section.

(2) The local health officer may approve installation of holding tank sewage systems only:

(a) For permanent uses limited to controlled, part-time, commercial usage situations, such as recreational vehicle parks and trailer dump stations;

(b) For interim uses limited to handling of emergency situations; or

(c) For repairs as permitted under WAC 246-272A-0280 (1)(d)(i).

(3) A person proposing to use a holding tank sewage system shall:

(a) Follow design criteria established by the department;

(b) Submit a management program to the local health officer assuring ongoing operation, monitoring, and maintenance before the local health officer issues the installation permit; and

(c) Use a holding tank reviewed and approved by the department.

[Statutory Authority: RCW 43.20.050(3), 43.20.065, chapters 70A.105 and 70A.110 RCW. WSR 24-06-046, § 246-272A-0240, filed 3/1/24, effective 4/1/25. Statutory Authority: RCW 43.20.050. WSR 05-15-119, § 246-272A-0240, filed 7/18/05, effective 7/1/07.]

WAC 246-272A-0250 Installation. (1) Only installers may construct OSS, except as noted under subsection (2) of this section.

(2) The local health officer may allow the resident owner of a single-family residence to install the OSS for that single-family residence except when:

(a) The primary and reserve areas are within 200 feet of marine water;

(b) The primary and reserve areas are within 100 feet of surface water; or

(c) The installation permit meets Table X standards in WAC 246-272A-0280.

(3) The installer described by either subsection (1) or (2) of this section shall:

(a) Follow the approved design;

(b) Have the approved design in possession during installation;

(c) Make no changes to the approved design without the prior authorization of the designer and the local health officer;

(d) Only install sewage tanks approved by the department consistent with chapter 246-272C WAC;

(e) Be on the site at all times during the excavation and construction of the OSS;

(f) Install the OSS to be watertight, except for the soil dispersal component;

(g) Cover the installation only after the local health officer has given approval to cover; and

(h) Back fill with six to 24 inches of cover material and grade the site to prevent surface water from accumulating over any component of the OSS.

[Statutory Authority: RCW 43.20.050(3), 43.20.065, chapters 70A.105 and 70A.110 RCW. WSR 24-06-046, § 246-272A-0250, filed 3/1/24, effective 4/1/25. Statutory Authority: RCW 43.20.050. WSR 05-15-119, § 246-272A-0250, filed 7/18/05, effective 7/1/07.]

WAC 246-272A-0260 Inspection. (1) For all activities requiring a permit, the local health officer shall inspect the OSS. The local health officer shall:

(a) Visit the OSS site during the site evaluation, construction, or final construction inspection;

(b) Either inspect the OSS before cover or allow the designer of the OSS to perform the inspection before cover if the designer is not also named as installer of the system; and

(c) Keep the record drawings on file, with the approved design documents.

(2) Prior to any inspection, the local health officer or inspector authorized by the local health officer shall coordinate with the OSS owner to obtain access. When the owner does not authorize access, the local health officer may follow the administrative search warrant procedures in RCW 70A.105.030 to gain access.

(3) For any OSS located on a single property serving one dwelling unit on the same property, the local health officer shall not require a property owner to grant inspection and maintenance easements as a condition of receiving a permit.

(4) During the final construction inspection, the local health officer or the designer of the OSS must confirm the OSS meets the approved design.

(5) To comply with the requirements of WAC 246-272A-0270 (1)(e) or (k), an inspection must include, at a minimum:

(a) Inspection and evaluation of:

(i) The status of all sewage tanks including baffles, effluent filters, tank contents such as water level, scum, sludge, solids, water tightness, and general structural conditions;

(ii) The status of all lids, accesses, and risers;

(iii) The OSS and reserve area for any indicators of OSS failure or conditions that may impact system function, operation, or repair; and

(iv) Any other components such as distribution boxes;

(b) A review of the record drawing and related documents, if they exist, including previous reports to confirm the system is operating as designed; and

(c) Any proprietary products following the procedures of the accepted operations and maintenance manual associated with those products.

(6) Evidence of an OSS property transfer inspection as required in WAC 246-272A-0270 (1)(k) must be provided to the local health jurisdiction on a form approved by the local health officer, including at a minimum:

(a) All applicable information from subsection (5) of this section;

(b) The address of the property served by the OSS;

(c) The date of the inspection;

(d) The permitted type and design flow for known OSS; and

(e) Verification that the record drawing is accurate, if it exists, or an OSS site plan showing the location of all system components relative to structures and prominent site features.

(7) A local health jurisdiction may require an additional inspection report, or additional information, for an inspection required under WAC 246-272A-0270(1). The person responsible for the final construction inspection shall assure the OSS meets the approved design.

[Statutory Authority: RCW 43.20.050(3), 43.20.065, chapters 70A.105 and 70A.110 RCW. WSR 24-06-046, § 246-272A-0260, filed 3/1/24, effective 4/1/25. Statutory Authority: RCW 43.20.050. WSR 05-15-119, § 246-272A-0260, filed 7/18/05, effective 7/1/07.]

WAC 246-272A-0265 Record drawings. Upon completion of new construction, alteration, or repair of the OSS, the OSS owner shall submit a complete and detailed record drawing to the local health officer that includes at a minimum:

(1) Measurements and directions accurate to +/- 1/2 foot, unless otherwise determined by the local health officer, so that the following parts of the OSS can be easily located:

(a) All sewage tank openings requiring access;

(b) The ends, and all changes in direction, of installed and found buried pipes and electrical cables that are part of the OSS; and

(c) Any other OSS component which, in the judgment of the local health officer or the designer, must be accessed for observation, maintenance, or operation;

(2) Location and dimensions of the reserve area;

(3) Record that materials and equipment meet the specifications contained in the design;

(4) Initial settings of electrical or mechanical devices that must be known to operate the system in the manner intended by the designer or installer; and

(5) For proprietary products, manufacturer's standard product literature, including performance specifications and maintenance recommendations needed for operation, monitoring, maintenance, or repair of the OSS.

[Statutory Authority: RCW 43.20.050(3), 43.20.065, chapters 70A.105 and 70A.110 RCW. WSR 24-06-046, § 246-272A-0265, filed 3/1/24, effective 4/1/25. Statutory Authority: RCW 43.20.050. WSR 05-15-119, § 246-272A-0265, filed 7/18/05, effective 7/1/07.]

WAC 246-272A-0270 Operation, monitoring, and maintenance—Owner responsibilities. (1) The OSS owner is responsible for operating, monitoring, and maintaining the OSS to minimize the risk of failure, and shall:

(a) Request assistance from the local health officer upon occurrence of a system failure or suspected system failure;

(b) Obtain approval from the local health officer before:

(i) Repairing, altering, or expanding an OSS as required by WAC 246-272A-0200; or

(ii) Before beginning the use of any newly constructed OSS;

(c) Secure and renew contracts for periodic maintenance if required by the local health jurisdiction;

- (d) Obtain and renew operation permits if required by the local health jurisdiction;
- (e) Obtain an inspection, as required in WAC 246-272A-0260(5), by a maintenance service provider authorized by the local health officer of all OSS and property to determine functionality, maintenance needs and compliance with this chapter and local rules, and any permits:
 - (i) At least once every three years, unless more frequent inspections are specified by the local health officer, for all OSS consisting solely of a sewage tank and gravity SSAS;
 - (ii) Annually for all other OSS unless more frequent inspections are specified by the local health officer;
 - (iii) Submit the results of the inspection to the local health jurisdiction, using a form approved by the local health officer and in compliance with WAC 246-272A-0260(5);
- (f) Employ an approved pumper to remove the septage from the tank when the level of solids and scum indicates that removal is necessary;
- (g) Provide ongoing maintenance and complete any needed repairs to promptly return the OSS to a proper operating condition;
- (h) Protect the OSS area and the reserve area from:
 - (i) Cover by structures or impervious material;
 - (ii) Surface drainage, and direct drains, such as footing or roof drains. The drainage must be directed away from the area where the OSS is located;
 - (iii) Soil compaction. For example by vehicular traffic or livestock; and
 - (iv) Damage by soil removal and grade alteration.
- (i) Keep the flow of sewage to the OSS at or below the approved operating capacity and sewage quality;
- (j) Operate and maintain OSS as directed by the local health officer; and
- (k) At the time of property transfer:
 - (i) Provide to the buyer, all available OSS maintenance and repair records in addition to the completed seller disclosure statement in accordance with chapter 64.06 RCW for residential real property transfers;
 - (ii) Beginning February 1, 2027, obtain an inspection, as required in WAC 246-272A-0260(5), by a third-party inspector authorized by the local health officer. The local health officer may:
 - (A) Remove the requirement for an inspection at the time of property transfer if the local health jurisdiction has evidence that the OSS is in compliance with (e) of this subsection and the OSS was inspected by a third-party inspector authorized by the local health officer;
 - (B) Verify the results of the property inspection for compliance with WAC 246-272A-0260; and
 - (C) Require additional inspections and other requirements not listed in WAC 246-272A-0260;
 - (iii) Beginning February 1, 2027, obtain an inspection of proprietary treatment products per the product manufacturer recommendations, as required in WAC 246-272A-0260, by a third-party inspector authorized by the local health officer. The local health officer may:
 - (A) Remove the requirement for an inspection at the time of property transfer if the local health jurisdiction has evidence that the OSS is in compliance with (e) of this subsection and the OSS was inspected by a third-party inspector authorized by the local health officer;

(B) Verify the results of the property inspection for compliance with WAC 246-272A-0260; and

(C) Require additional inspections and other requirements not listed in WAC 246-272A-0260;

(iv) Submit the results of the inspection, and any additional information or reports required by the local health officer, to the local health jurisdiction, using an inspection report form approved by the local health officer. The local health officer may require a compliance schedule for repair of a failure discovered during the property transfer inspection.

(2) A person may not:

(a) Use or introduce strong bases, acids, or chlorinated organic solvents into an OSS for the purpose of system cleaning;

(b) Use an OSS additive unless it is specifically approved by the department;

(c) Use an OSS to dispose of waste components atypical of sewage from a residential source; or

(d) Use any remediation process or activity unless it is approved by the local health officer and is in compliance with WAC 246-272A-0278.

[Statutory Authority: RCW 43.20.050(3), 43.20.065, chapters 70A.105 and 70A.110 RCW. WSR 24-06-046, § 246-272A-0270, filed 3/1/24, effective 4/1/25. Statutory Authority: RCW 43.20.050. WSR 05-15-119, § 246-272A-0270, filed 7/18/05, effective 7/1/07.]

WAC 246-272A-0275 Operation, monitoring, and maintenance—Food service establishments. The local health officer shall require annual inspections of OSS serving food service establishments and may require pumping as needed.

[Statutory Authority: RCW 43.20.050. WSR 05-15-119, § 246-272A-0275, filed 7/18/05, effective 7/1/07.]

WAC 246-272A-0278 Remediation. (1) The local health officer may establish a program and requirements for reviewing and approving remediation activities.

(2) Remediation must not:

(a) Result in damage to the OSS;

(b) Result in insufficient soil treatment in the zone between the soil dispersal component and the highest seasonal water table, restrictive layer, or soil type 7; or

(c) Disturb the soil in or below the soil dispersal component if the vertical separation requirements of WAC 246-272A-0230 are not met.

[Statutory Authority: RCW 43.20.050(3), 43.20.065, chapters 70A.105 and 70A.110 RCW. WSR 24-06-046, § 246-272A-0278, filed 3/1/24, effective 4/1/25.]

WAC 246-272A-0280 Repair of failures. (1) When an OSS failure occurs the local health officer shall:

- (a) Allow an OSS to be repaired using the least costly alternative that meets standards and is likely to provide comparable or better long-term sewage treatment and effluent dispersal outcomes;
 - (b) Permit an OSS meeting the requirements in Table X of this section only if the OSS has failed and the following are not feasible:
 - (i) Installation of a conforming OSS or component; or
 - (ii) Connection to either an approved LOSS or a public sewer.
 - (c) Identify repair permits meeting the requirements in Table X of this section for the purpose of tracking future performance;
 - (d) Give first priority to allowing repair and second priority to allowing replacement of an existing conventional OSS, consisting of a septic tank and drainfield, with a similar conventional OSS;
 - (e) Evaluate all unpermitted sewage discharges to determine if they pose a public health threat. If determined by the local health officer to be a public health threat, the local health officer shall require a compliance schedule;
 - (f) Report failures within 200 feet of shellfish growing areas to the department; and
 - (g) Not impose or allow the imposition of more stringent performance requirements of equivalent OSS on private entities than public entities.
- (2) The local health officer may:
- (a) Require a compliance schedule for failures discovered during property transfer inspections;
 - (b) Allow a repair of a failure using ASTM C-33 sand or coarser as fill to prevent direct discharge of treated effluent to groundwater, surface water, or upon the surface of the ground if the vertical separation is less than 12 inches.
- (3) The OSS owner shall notify the local health officer when there is a failure and indicate which methods will be used to address the failure in accordance with Table IX of this section:
- (a) The owner may use option D only if the local health officer determines options A through C are not feasible and may use option E or F only if options A through D are not feasible.
 - (b) For options A through F, the owner shall develop and submit information and obtain a permit as required under WAC 246-272A-0200 prior to any repair or replacement of an OSS on the property served or a nearby property if the owner obtains an appropriate documentation including, but not limited to, an easement, covenant, contract, or other legal document authorizing access for construction, operation, maintenance, and repair.
 - (c) If options A through F are not feasible, the owner shall discontinue use of the OSS, abandon the OSS according to the requirements in WAC 246-272A-0300, and cease all sewage generating activities on the property.

**Table IX
Options and Methods to Address an OSS Failure**

Options	Method
A	Repair or replace the OSS, with a similar OSS, if the OSS provides comparable or better long-term sewage treatment and effluent dispersal outcomes where: <ol style="list-style-type: none"> 1. The effluent treatment and soil dispersal component to be repaired or replaced is not closer to any surface water, well, or spring than the minimum separation distance required in Table IV of WAC 246-272A-0210(1); 2. The soil dispersal component to be repaired or replaced complies with the treatment level and distribution method requirements in Table VI of WAC 246-272A-0230;

Options	Method
	3. The local health officer has a permit or record of the OSS on file; and 4. The repair or replacement will not result in an OSS that meets the definition of failure.
B	Repair or replace the OSS with an OSS in compliance with new construction requirements under this chapter.
C	Connect the residence or facility to a: <ol style="list-style-type: none"> 1. Publicly owned LOSS; 2. Privately owned LOSS where it is deemed economically feasible; or 3. Public sewer.
D	Repair or replace the OSS in conformance with Table X of this section.
E	Use a holding tank.
F	Obtain a National Pollution Discharge Elimination System or state discharge permit from the Washington state department of ecology issued to a public entity or jointly to a public entity and the OSS owner only when the local health officer determines: <ol style="list-style-type: none"> 1. An OSS is not feasible; and 2. The only realistic method of final dispersal of treated effluent is discharge to the surface of the land or into surface water.

(4) When there is an OSS failure, the OSS designer shall:

- (a) Evaluate the causes of failure prior to designing the repair or replacement of the OSS;
- (b) Prevent the direct discharge of sewage or treated effluent to groundwater, surface water, or upon the surface of the ground;
- (c) Meet the horizontal separations under WAC 246-272A-0210(1) to public drinking water sources;
- (d) Protect all drinking water sources, shellfish harvesting areas, and water recreation facilities designated for swimming in natural waters;
- (e) Minimize nitrogen discharge in areas where nitrogen has been identified as a contaminant of concern in the local management plan under WAC 246-272A-0015;
- (f) Not use disinfection to achieve fecal coliform or *E. coli* requirements in Table X of this section to meet:
 - (i) Treatment level BL1 or BL2 with less than 18 inches of vertical separation; or
 - (ii) Treatment level BL1 or BL2 in type 1 soils; or
 - (iii) Treatment level BL3.
- (g) Minimize impact of phosphorus discharge in areas where the local health officer has identified phosphorus as a contaminant of concern in the local management plan under WAC 246-272A-0015;
- (h) Locate and design repairs meeting the requirements in Table X of this section if the effluent treatment and soil dispersal component to be repaired or replaced is closer to any surface water, well, or spring than prescribed by the minimum separation required in Table IV of WAC 246-272A-0210(1);
 - (i) Design any nonconforming OSS using pressure distribution with timed dosing in the soil dispersal component; and
 - (j) Meet all other design requirements of this chapter to the maximum extent permitted by the site, to maximize the:
 - (i) Vertical separation;
 - (ii) Distance from a well or spring; and
 - (iii) Distance to surface water.

Table X
Treatment Component Performance Levels for Repair of OSS Not Meeting Vertical and Horizontal Separations¹

Vertical Separation (in inches)	Horizontal Separation ²											
	< 30 feet			≥ 30 < 50 feet			≥ 50 < 100 feet ³			≥ 100 feet		
	Soil Type			Soil Type			Soil Type			Soil Type		
	1	2	3-6	1	2	3-6	1	2	3-6	1	2	3-6
< 12	A & BL1	A & BL1	A & BL1	A & BL1	A & BL1	A & BL1	A & BL1	A & BL1	A & BL1	B & BL2	B & BL2	B & BL2
≥ 12 < 18	A & BL1	A & BL1	A & BL1	A & BL1	B & BL2	B & BL2	A & BL1	B & BL2	B & BL2	Conforming OSS		
≥ 18 < 24	A & BL1	A & BL1	A & BL1	A & BL1	B & BL2	B & BL2	A & BL1	B & BL2	B & BL2			
≥ 24 < 36	A & BL1	B & BL2	B & BL2	B & BL2	B & BL2	B & BL2	B & BL2	B & BL2	C & BL3			
≥ 36	A & BL1	B & BL2	B & BL2	B & BL2	C & BL3	C & BL3	B & BL2	C & BL3	C & BL3			

¹ The treatment component performance levels correspond with those established for treatment components under the product performance testing requirements in Table III in WAC 246-272A-0110.

² The horizontal separation indicated in Table X of this section is the distance between the soil dispersal component and the surface water, well, or spring. If the soil dispersal component is up-gradient of a surface water, well, or spring to be used as a potable water source, or beach where shellfish are harvested, the next higher treatment level shall apply unless treatment level A and BL1 is already required.

³ On a site where there is a horizontal setback of 75-100 feet between an OSS dispersal component and an individual water well, individual spring, nonmarine surface water or surface water that is not a public water source and a vertical separation of greater than 12 inches, a conforming OSS that complies with WAC 246-272A-0210(4) shall be installed if feasible.

[Statutory Authority: RCW 43.20.050(3), 43.20.065, chapters 70A.105 and 70A.110 RCW. WSR 24-06-046, § 246-272A-0280, filed 3/1/24, effective 4/1/25. Statutory Authority: RCW 43.20.050. WSR 05-15-119, § 246-272A-0280, filed 7/18/05, effective 7/1/07.]

WAC 246-272A-0282 Minor repair of malfunctions. The local health officer:

- (1) Shall require the minor repair of a malfunction to a functioning state;
- (2) May require a permit for a minor repair of a malfunction; and
- (3) May require the OSS owner to submit information regarding minor repairs of a malfunction.

[Statutory Authority: RCW 43.20.050(3), 43.20.065, chapters 70A.105 and 70A.110 RCW. WSR 24-06-046, § 246-272A-0282, filed 3/1/24, effective 4/1/25.]

WAC 246-272A-0290 Expansions. (1) The local health officer shall require an OSS and a reserve area in full compliance with the new construction standards specified in this chapter for an OSS expansion.

(2) A local health officer may allow expansion of an existing OSS within 200 feet of a marine shoreline that does not meet the minimum horizontal separation between the soil dispersal component and the ordinary high-water mark required by WAC 246-272A-0210, Table IV, provided that:

- (a) The OSS meets all requirements of WAC 246-272A-0230, 246-272A-0232, 246-272A-0234, and 246-272A-0238;
- (b) The OSS complies with all other requirements of WAC 246-272A-0210 and this section;
- (c) Horizontal separation between the soil dispersal component and the ordinary high-water mark is 50 feet or greater; and

(d) Vertical separation is two feet or greater.

[Statutory Authority: RCW 43.20.050(3), 43.20.065, chapters 70A.105 and 70A.110 RCW. WSR 24-06-046, § 246-272A-0290, filed 3/1/24, effective 4/1/25. Statutory Authority: RCW 43.20.050. WSR 05-15-119, § 246-272A-0290, filed 7/18/05, effective 7/1/07.]

WAC 246-272A-0300 Abandonment. Persons permanently abandoning a sewage tank, seepage pit, cesspool, or other sewage container shall:

- (1) Have the septage removed by an approved pumper; and
- (2) Perform one of the following:
 - (a) Remove and dispose of sewage tanks and other components in a manner approved by the local health officer; or
 - (b) Leave the sewage tanks and components in place. Remove or destroy the lid if possible and fill the void with soil or gravel; and
- (3) Grade the site to the surroundings.

[Statutory Authority: RCW 43.20.050(3), 43.20.065, chapters 70A.105 and 70A.110 RCW. WSR 24-06-046, § 246-272A-0300, filed 3/1/24, effective 4/1/25. Statutory Authority: RCW 43.20.050. WSR 05-15-119, § 246-272A-0300, filed 7/18/05, effective 7/1/07.]

WAC 246-272A-0310 Septage management. A person removing septage from an OSS shall obtain approval from the local health officer before removal and:

- (1) Transport septage or sewage only in vehicles clearly identified with the name of the business and approved by the local health officer;
- (2) Record and report septage removal as required by the local health officer; and
- (3) Dispose of septage, or apply septage biosolids to land only in a manner consistent with applicable laws.

[Statutory Authority: RCW 43.20.050(3), 43.20.065, chapters 70A.105 and 70A.110 RCW. WSR 24-06-046, § 246-272A-0310, filed 3/1/24, effective 4/1/25. Statutory Authority: RCW 43.20.050. WSR 05-15-119, § 246-272A-0310, filed 7/18/05, effective 7/1/07.]

WAC 246-272A-0320 Developments, subdivisions, and minimum land area requirements. (1) Prior to approving any development, the local health officer shall:

- (a) Require site evaluations under WAC 246-272A-0220;
- (b) Require information consisting of field data, plans, and reports supporting a conclusion that the proposed land area is sufficient to:
 - (i) Install conforming OSS;
 - (ii) Preserve reserve areas for proposed and existing OSS; and
 - (iii) Properly treat and dispose of the sewage;
- (c) Require information demonstrating that the proposed development will minimize adverse public health effects from the accumulation of contaminants in groundwater and surface water;
- (d) Determine the minimum land area required for the development using Table XI of this section, or the alternative methodology in Table XII of this section. The local health officer may require larger

lot sizes than the minimum standards established in Table XI or Table XII of this section;

**Table XI
Minimum Land Area Requirement For Each Single-Family Residence or Unit
Volume of Sewage and Minimum Usable Land Area**

		Soil Type (defined by WAC 246-272A-0220)					
		1	2	3	4	5	6
Minimum Land Area	Public Water Supply	21,780 sq. ft. (0.5 acre)	13,000 sq. ft.	16,000 sq. ft.	19,000 sq. ft.	21,000 sq. ft.	23,000 sq. ft.
		2.5 acres ¹					
	Nonpublic Water Supply	1.0 acre	1.0 acre	1.0 acre	1.0 acre	2.0 acres	2.0 acres
		2.5 acres ¹					
Minimum Usable Land Area		2,000 sq. ft.	2,000 sq. ft.	2,500 sq. ft.	3,333 sq. ft.	5,000 sq. ft.	10,000 sq. ft.

¹ OSS consisting of only sewage tanks and gravity SSAS must have a minimum land area of 2.5 acres per WAC 246-272A-0234(7).

**Table XII
Maximum Allowable Total Nitrogen (TN) Load Per Day by Type of Water Supply, Soil Type, and Land Area¹**

Water Supply Type	Maximum Daily TN Load	Soil Type ²					
		1	2	3	4	5	6
Public	mg per sq. ft.	3.8	6.3	5.1	4.3	3.9	3.6
	lb per acre	0.36	0.60	0.49	0.41	0.37	0.34
Nonpublic	mg per sq. ft.	1.9	1.9	1.9	1.9	0.9	0.9
	lb per acre	0.18	0.18	0.18	0.18	0.09	0.09

¹ Based on 60 mg/L TN and 360 gal/day OSS effluent.

² As defined in Table V in WAC 246-272A-0220.

(e) Require all proposals not meeting the minimum land area requirements in Table XI of this section to demonstrate the proposed development:

(i) Minimizes adverse impacts to public health, surface water, or groundwater quality;

(ii) Considers:

(A) Topography, geology, and ground cover;

(B) Climactic conditions;

(C) Availability of public sewers; and

(D) Present and anticipated land use and growth patterns;

(iii) Complies with current planning and zoning requirements;

(iv) Does not exceed the nitrogen limit per land area as identified in Table XII of this section; and

(v) Does not allow new lots smaller than 13,000 square feet if served by nonpublic water supplies;

(f) Require minimum land area of 13,000 square feet or larger, except when a proposal includes:

(i) OSS within the boundaries of a recognized sewer utility having a finalized assessment roll; or

(ii) A planned unit development with a signed, notarized, and recorded deed covenant restricting any development of lots or parcels above the approved density with the overall density meeting the minimum land area requirements of (d) or (e) of this subsection in perpetuity or until the OSS is no longer needed as identified in WAC 246-272A-0200 (6);

(g) Require that developments other than single-family residences:

(i) Meet the minimum land areas required for each unit's volume of sewage;

(ii) Do not exceed 3.35 unit volumes of sewage per day per acre if served by public water supplies; and

(iii) Do not exceed 1.0 unit volume of sewage per day per acre for nonpublic water supplies; and

(h) Require that the use of a reduced-sized dispersal component does not result in a reduction of the minimum land area requirements established in this section.

(2) The local health officer shall require the following prior to approving any subdivision:

(a) A recommendation for approval as required by RCW 58.17.150;

(b) Where a subdivision with nonpublic wells are proposed:

(i) Configuration of each lot line to allow a supply protection zone to fit within the lot lines; or

(ii) Water supply protection zones on more than one lot when the person proposing the subdivision or development provides a copy of a recorded restrictive covenant to each property that is sited partially or completely within the water supply protection zone;

(iii) Water supply protection zone of at least 100 foot radius for each existing or proposed well site.

(3) The local health officer may:

(a) Require detailed site plans and OSS designs prior to final approval of subdivision proposals;

(b) Require larger land areas or lot sizes to achieve public health protection;

(c) Prohibit development on individual lots within the boundaries of an approved subdivision if the proposed OSS design does not meet the requirements of this chapter; and

(d) Permit the installation of an OSS, where the minimum land area requirements or lot sizes in Table XI of this section or maximum total nitrogen in Table XII of this section cannot be met, only when the following criteria are met:

(i) The lot is registered as a legal lot of record created prior to the effective date of the rule;

(ii) The lot is not within an area identified in the local management plan developed under WAC 246-272A-0015 where minimum land area is listed as a design parameter necessary for public health protection; and

(iii) The proposed OSS meets all requirements of this chapter without the use of a waiver under WAC 246-272A-0420.

[Statutory Authority: RCW 43.20.050(3), 43.20.065, chapters 70A.105 and 70A.110 RCW. WSR 24-06-046, § 246-272A-0320, filed 3/1/24, effective 4/1/25. Statutory Authority: RCW 43.20.050. WSR 05-15-119, § 246-272A-0320, filed 7/18/05, effective 7/1/07.]

WAC 246-272A-0340 Approval of installers, pumpers, and maintenance service providers. (1) OSS installers, pumpers, and maintenance service providers shall obtain approval from the local health officer prior to providing services including, but not limited to, conducting inspections in accordance with WAC 246-272A-0260 and 246-272A-0270, within a local health jurisdiction.

(2) The local health officer shall establish procedures for approving OSS installers, pumpers, and maintenance service providers no later than February 1, 2025. These procedures must include, but are not limited to, conducting inspections in accordance with WAC 246-272A-0260 and 246-272A-0270. The local health officer may approve OSS installers, pumpers, and maintenance service providers through reciprocity by other Washington local health jurisdictions.

(3) The local health officer may establish a homeowner OSS inspection certification process.

[Statutory Authority: RCW 43.20.050(3), 43.20.065, chapters 70A.105 and 70A.110 RCW. WSR 24-06-046, § 246-272A-0340, filed 3/1/24, effective 2/1/25. Statutory Authority: RCW 43.20.050. WSR 05-15-119, § 246-272A-0340, filed 7/18/05, effective 7/1/07.]

WAC 246-272A-0400 Technical advisory group (TAG). The department shall:

(1) Maintain a TAG to advise the department regarding:
(a) OSS design and siting;
(b) Public domain technologies, DS&G for product use; and
(c) Testing and design standards used for proprietary product registration and DS&G for use of proprietary products.

(2) Select members for the TAG for three-year terms that have technical or scientific knowledge applicable to OSS from agencies, professions, and organizations including:

- (a) Local health jurisdictions;
- (b) Engineering firms;
- (c) The Washington department of ecology;
- (d) Land sales, development and building industries;
- (e) Public sewer utilities;
- (f) OSS:
 - (i) Designers;
 - (ii) Installers;
 - (iii) Maintenance service providers;
 - (iv) Product manufacturers;
- (g) Environmental organizations;
- (h) University and college academic communities;
- (i) Certified professional soil scientists; and
- (j) Other interested organizations or groups.

[Statutory Authority: RCW 43.20.050(3), 43.20.065, chapters 70A.105 and 70A.110 RCW. WSR 24-06-046, § 246-272A-0400, filed 3/1/24, effective 4/1/25. Statutory Authority: RCW 43.20.050. WSR 05-15-119, § 246-272A-0400, filed 7/18/05, effective 9/15/05.]

WAC 246-272A-0410 Policy advisory group. The department shall:

(1) Maintain a policy advisory group to:
(a) Make recommendations concerning OSS departmental policy and rules;
(b) Review OSS program services; and
(c) Provide input to the department regarding the OSS program;
(2) Select members for three-year terms from agencies, professions, organizations having knowledge and interest in OSS, and communities which are affected by this chapter.

[Statutory Authority: RCW 43.20.050(3), 43.20.065, chapters 70A.105 and 70A.110 RCW. WSR 24-06-046, § 246-272A-0410, filed 3/1/24, effective 4/1/25. Statutory Authority: RCW 43.20.050. WSR 05-15-119, § 246-272A-0410, filed 7/18/05, effective 9/15/05.]

WAC 246-272A-0420 Waivers. (1) The local health officer may grant a waiver from specific requirements of this chapter. A request for waiver must be:

(a) Evaluated by the local health officer on an individual, site-by-site basis;

(b) Consistent with the purposes of this chapter.

(2) (a) The local health officer must submit quarterly reports to the department showing waivers approved or denied.

(b) Upon review, if the department finds that the waivers previously granted are inconsistent, with the purposes of this chapter, and DS&G for granting waivers, the department shall provide technical assistance to the local health officer to correct the inconsistency, and may notify the local and state boards of health of the department's concerns.

(c) If upon further review, the department finds waivers previously granted continue to be inconsistent with the purposes of this chapter and DS&G, the department may suspend the authority of the local health officer to grant waivers under this section until such inconsistencies have been corrected.

(3) The department shall maintain and update guidance to assist local health officers in the application of waivers.

(4) The department shall publish an annual report summarizing the waivers issued over the previous year.

[Statutory Authority: RCW 43.20.050(3), 43.20.065, chapters 70A.105 and 70A.110 RCW. WSR 24-06-046, § 246-272A-0420, filed 3/1/24, effective 4/1/25. Statutory Authority: RCW 43.20.050. WSR 05-15-119, § 246-272A-0420, filed 7/18/05, effective 9/15/05.]

WAC 246-272A-0425 Required review of rules. The department shall review this chapter to evaluate the effectiveness of the rules, determine where revisions may be necessary, and make recommendations to the state board of health and all local health officers by September 2026 and every four years thereafter.

[Statutory Authority: RCW 43.20.050(3), 43.20.065, chapters 70A.105 and 70A.110 RCW. WSR 24-06-046, § 246-272A-0425, filed 3/1/24, effective 4/1/25. Statutory Authority: RCW 43.20.050. WSR 05-15-119, § 246-272A-0425, filed 7/18/05, effective 9/15/05.]

WAC 246-272A-0430 Enforcement. (1) When an OSS is out of compliance with any law or rule regulating OSS and administered by the department or the local health officer, the department or the local health officer may initiate enforcement action. Enforcement action may include, but is not necessarily limited to:

(a) A notice of correction describing the condition that is not in compliance and the text of the specific section or subsection of the applicable state or federal law or rule, a statement of what is

required to achieve compliance, and the date by which compliance is to be achieved;

(b) A notice of violation with or without a civil penalty;

(c) An order requiring specific actions or ceasing unacceptable activities within a designated time period;

(d) Suspension, revocation, or modification or denial of permits and licenses as authorized by RCW 43.70.115; and

(e) Civil or criminal penalties authorized under chapter 70.05 RCW and RCW 43.70.190.

(2) An informal conference may be held at the request of any party to resolve disputes arising from enforcement of this chapter.

(3) Notices and orders issued under this section must:

(a) Be in writing;

(b) Name the person or persons to whom the order is directed;

(c) Briefly describe each action or inaction constituting a violation of the rules of chapter 246-272A WAC, or applicable local rules;

(d) Specify any required corrective action, if applicable;

(e) Specify the effective date of the order, with time or times of compliance;

(f) Provide notice of the consequences of failure to comply or repeated violation, as appropriate.

(4) Enforcement orders must be personally served in the manner of service of a summons in a civil action or in another manner showing proof of receipt.

(5) The department shall have cause to deny the application or reapplication for a permit or to revoke, suspend, or modify a required permit of any person who has:

(a) Failed or refused to comply with the provisions of chapter 246-272A WAC, or any other statutory provision or rule regulating the operation of an OSS; or

(b) Obtained or attempted to obtain a permit or any other required certificate or approval by misrepresentation.

[Statutory Authority: RCW 43.20.050(3), 43.20.065, chapters 70A.105 and 70A.110 RCW. WSR 24-06-046, § 246-272A-0430, filed 3/1/24, effective 4/1/25. Statutory Authority: RCW 43.20.050. WSR 05-15-119, § 246-272A-0430, filed 7/18/05, effective 9/15/05.]

WAC 246-272A-0440 Notice of decision—Adjudicative proceeding.

(1) All local boards of health shall:

(a) Maintain an adjudicative process to resolve procedural and technical conflicts arising from the administration of local regulations; and

(b) Establish rules for conducting hearings requested to contest a local health officer's actions.

(2) The department shall provide notice of the department's denial, suspension, modification, or revocation of a permit, certification, or approval consistent with RCW 43.70.115, chapter 34.05 RCW, and chapter 246-10 WAC.

(3) A person contesting a departmental decision regarding a permit, certificate, or approval may file a written request for an adjudicative proceeding consistent with chapter 246-10 WAC.

(4) Department actions are governed by chapter 34.05 RCW, RCW 43.70.115, this chapter, and chapter 246-10 WAC.

[Statutory Authority: RCW 43.20.050(3), 43.20.065, chapters 70A.105 and 70A.110 RCW. WSR 24-06-046, § 246-272A-0440, filed 3/1/24, effective 4/1/25. Statutory Authority: RCW 43.20.050. WSR 05-15-119, § 246-272A-0440, filed 7/18/05, effective 9/15/05.]

WAC 246-272A-0450 Severability. If any provision of this chapter or its application to any person or circumstances is held invalid, the remainder of this chapter, or the application of the provision to other persons or circumstances shall not be affected.

[Statutory Authority: RCW 43.20.050. WSR 05-15-119, § 246-272A-0450, filed 7/18/05, effective 9/15/05.]